



FIBERLIGN® Suspension for OPGW & ADSS With AGIBS Enhanced Corrosion System

Be sure to read and completely understand this procedure before applying product. Be sure to select the proper PREFORMED product before application.

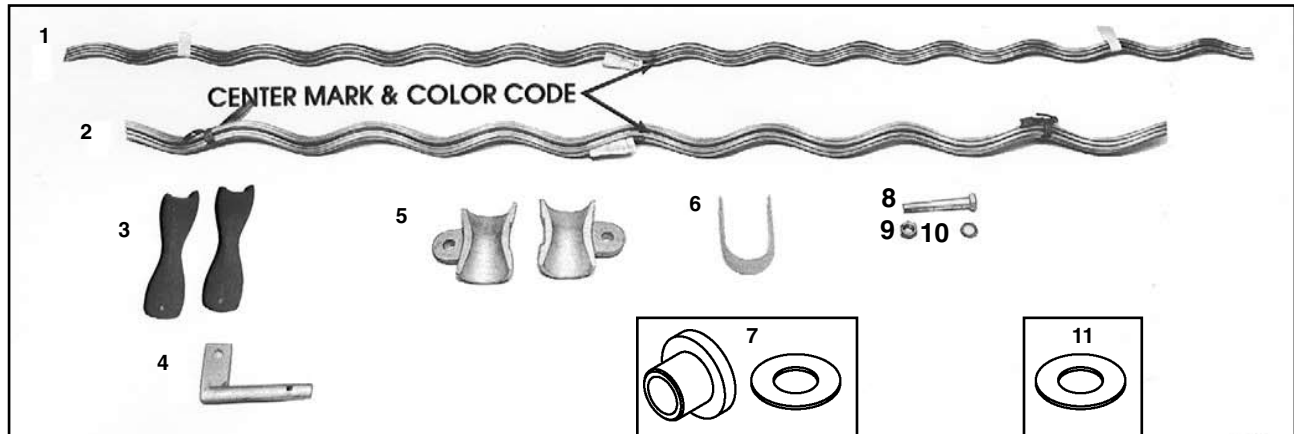

FIGURE 1 - NOMENCLATURE

1.00 NOMENCLATURE

1. Suspension Structural Reinforcing Rods (supplied for dual rod layer suspension assemblies only)
2. Suspension Rods
3. Suspension Inserts
4. Current Transfer Tab (supplied for OPGW enhanced corrosion resistant hardware installations with AGIBS)
5. Suspension Housing
6. Suspension Strap
7. Galvanic Isolation Bushing and Washer: Aerial Galvanic Isolation Bushing Systems (AGIBS™) (For enhanced corrosion resistant hardware and associated inhibitor installations only)
8. Suspension Bolt
9. Suspension Lock Nut
10. Suspension Lock Washer
11. Galvanized Steel Flat Washer

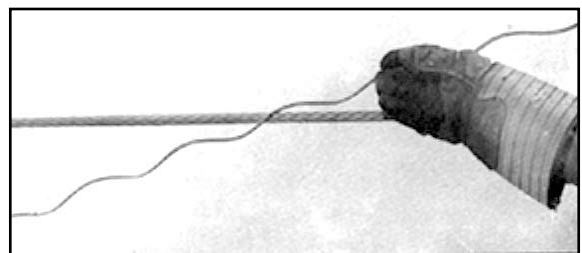

FIGURE 2

NOTE: Leave the last 10 - 14 inches on both ends of the Suspension Reinforcing Rods loose temporarily. This will enable you to check that a rod has not shifted, or "walked", on the cable and will allow simplified final make-up.

2.00 STRUCTURAL REINFORCING ROD APPLICATION

- 2.01 Plumb suspension and mark OPGW or ADSS cable at center of sheave. Use felt marking pen or lumber crayon; do not scratch. Lift the cable beyond the ends of the rods to allow sufficient clearance for the application.
- 2.02 Apply the factory marked center line of the first Suspension Structural Reinforcing Rod to the center of the cable. Wrap the first rod around the cable. (Figure 2)

- 2.03 Apply all remaining reinforcing rods around the cable. When most of the rods are applied and most gaps are closed, the remaining rods are designed to push between rods already applied and present a strong, armored reinforcement. (Figure 3)

NOTE: Make sure that no rods are crossed and that all rods are evenly spaced.



FIGURE 3

PLP Tip: Be sure that the alignment of all rod ends is maintained within 2". Remove and reapply any rods which exceed this limit.

- 2.04** To complete application, use both hands to wrap reinforcing rods simultaneously into position. Do first one end bundle, then the other end. (Figure 4)
Ends must be snapped into place.

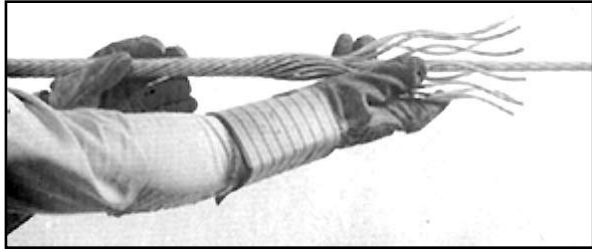

FIGURE 4

NOTE: FIBERLIGN Suspension Structural Reinforcing Rods are not interchangeable with standard Armor Rods or ARMOR-GRIP® suspension rods. The sets are factory matched so make sure the sets do not become intermixed and do not apply more rods than supplied in the set.

3.00 INSERT CURRENT TRANSFER TAB AND FIBERLIGN SUSPENSION ROD APPLICATION

- 3.01** Align the center marks of the inserts with the center line of the applied reinforcing rods. **NOTE:** For single layer suspension applications, place a mark on the OPGW where the center of the suspension is to be located and align the center marks of the inserts with this mark. Be sure to position inserts so that the joining faces are parallel to the ground. Tape in place with a thin layer of tape. (Figure 5)

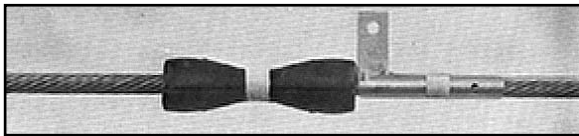

FIGURE 5

- 3.02** Position the current transfer tab with the short leg of the tab within one inch of the insert or as shown bearing lightly against the insert in Figure 5. Tape in place with a thin piece of tape. The tab may be positioned with short legs down or in any convenient position.

NOTE: current transfer tabs are required for OPGW enhanced corrosion resistant hardware installations that implement Aerial Galvanic Isolation Bushing Systems (AGIBS). current transfer tabs are not required for ADSS installations. For ADSS installations, omit this step and any other current transfer tab instructions.

PLP Tip: For OPGW, scratch-brushing and the use of an inhibitor are recommended to maintain good electrical contact between the current transfer tab and the Structural reinforcing rods.

- 3.03** Center the first Suspension Rod on the insert with the color mark positioned out and wrap over the insert and the current transfer tab. Apply sufficient length of rod to assure stability, leaving final foot or so on each end temporarily free. (Figures 5a, 5b and 6)

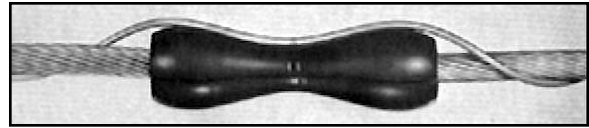

FIGURE 5a - PROPER APPLICATION

NOTE: The curvature of the rod follows the contour of the neoprene insert. **Make certain that there is no space between the rod and insert.**



**FIGURE 5b - IMPROPER APPLICATION
DO NOT WRAP THE ROD AROUND THE NEOPRENE INSERT AS SHOWN**

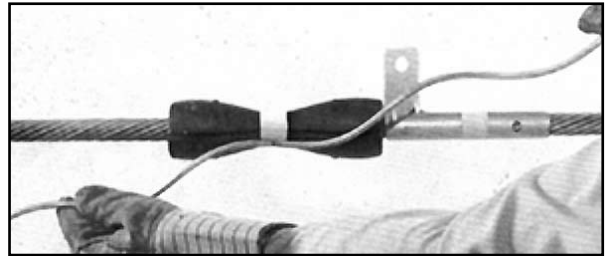

FIGURE 6

- 3.04** Apply the second rod on the opposite side of the short leg of the current transfer tab so that the tab extends through the gap between the two rods. Apply remaining rods at equal intervals and snap ends into place. (Figure 7)

Do not overlap, cross or distort rods

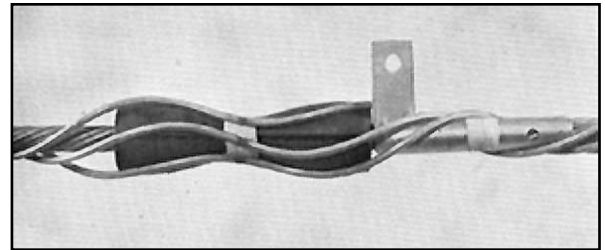

FIGURE 7

PLP Tip: As more rods are applied, trace the gaps between rods back to the inset to determine proper placement of subsequent rods. Apply the last rod to the largest remaining gap. Its pressure will cause all rods to space themselves uniformly around the cable.

- 3.05** Using both hands, encircle the free rod ends at one end of the application. Twist all rod ends into position simultaneously. Repeat process at other end. Check to be sure that the insert has remained perpendicular to the plumb. (Figure 8)

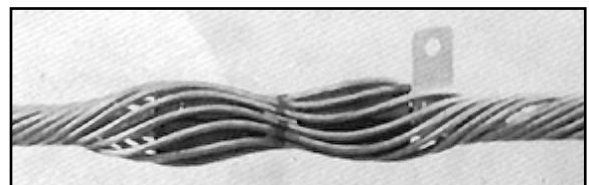

FIGURE 8

- 3.06 Place the Suspension Housing on both sides of the neoprene insert and rod assembly with the bolt hole facing up. Slide the Suspension Strap into position around the housing. Tap firmly into place with the heel of your hand. (Figure 9)

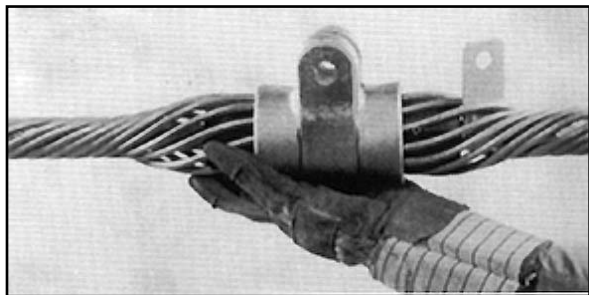

FIGURE 9

- 3.07 Spread the ears of the housing and tap strap into position again. This will assist alignment so that the bolt can be easily inserted.

NOTE: For AGIBS enhanced corrosion resistant hardware applications, go to Step 4.00 to continue installation.

- 3.08 Slide the bolt into position through the strap and housing. Apply the lock washer. (Figure 10)



FIGURE 10

- 3.09 Apply the locking nut. Tighten until the lock washer is almost flat. (Figure 11)

NOTE: Do not over tighten. Do not squeeze ears of housing against attachment fitting.

PLP Tip: Be sure that the locking tab on the nut faces the end of the bolt. The locking tab is designed to prevent the nut from backing off during vibration.

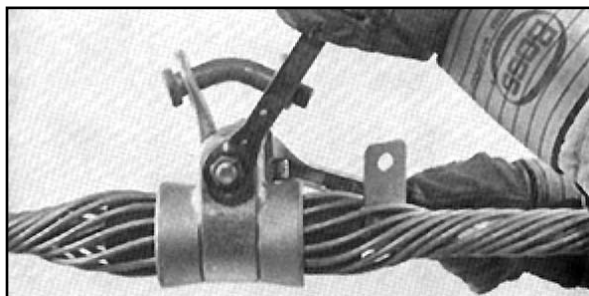

FIGURE 11

- 3.10 Attach bonding strap to current transfer tab using suitable bolt, nut and washer. Check completed application. (Figure 12)

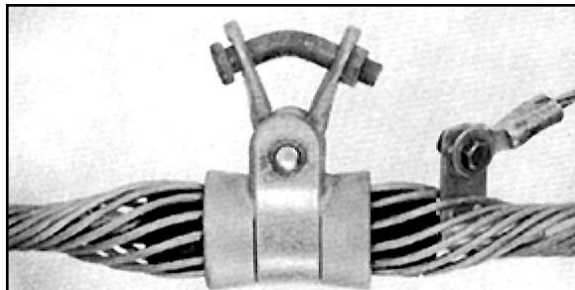

FIGURE 12

4.00 AGIBS, ENHANCED CORROSION RESISTANT HARDWARE APPLICATION

Caution: Suspensions with AGIBS are custom designed to meet specific strength requirements in high corrosion environments. The AGIBS vertical load rating can be less than 40% of a standard FIBERLIGN Suspension rating. **Prior to installation, verify that the proper suspension has been selected for your application.**

- 4.01 Once the strap is aligned with the housing, insert the flanged isolation bushings into the bolt holes of the strap and housing. (Figure 13)

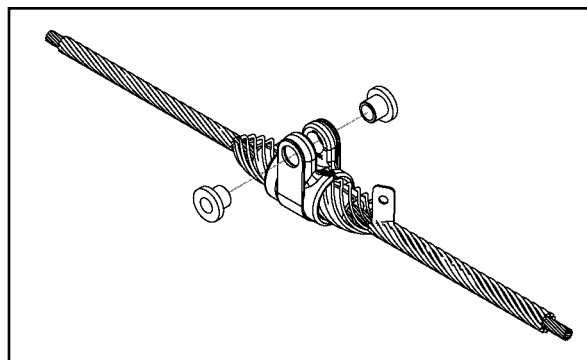

FIGURE 13

- 4.02 Place an isolation washer on both sides of the hardware fitting (anchor shackle, Y-clevis, etc.) and position the hardware fitting and isolation washers between the ears of the housing. (Figure 14)

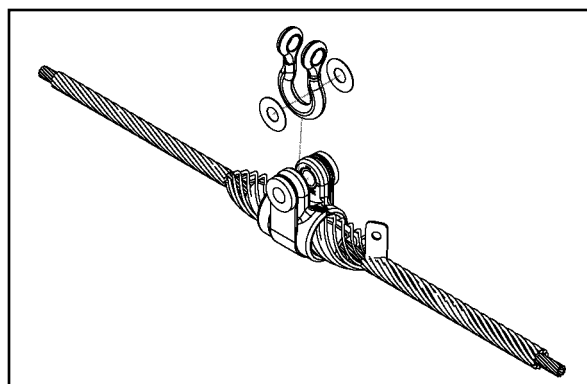

FIGURE 14

- 4.03 Slide the bolt through the galvanized steel flat washers, flanged isolation bushings, isolation washers, and hardware fitting. Then apply the lock washer and locking nut on the other end of the bolt. (Figure 15)

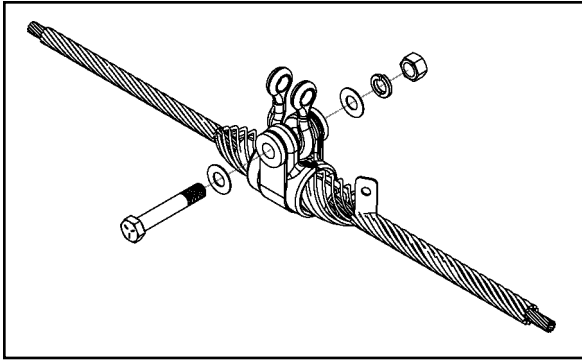

FIGURE 15

NOTE: The galvanized steel flat washers, lay flush against the flanged isolation bushings for protection upon installation of the bolt and nut. Tighten the lock nut until the lock washer is almost flat.

Do not overtighten the lock nut.

PLP TIP: Be sure that the locking tab on the nut faces the end of the bolt. The locking tab is designed to prevent the nut from backing off during vibration.

- 4.04 Attach bonding strap to current transfer tab using suitable bolt, nut and washer. Check completed application. (Figure 16)

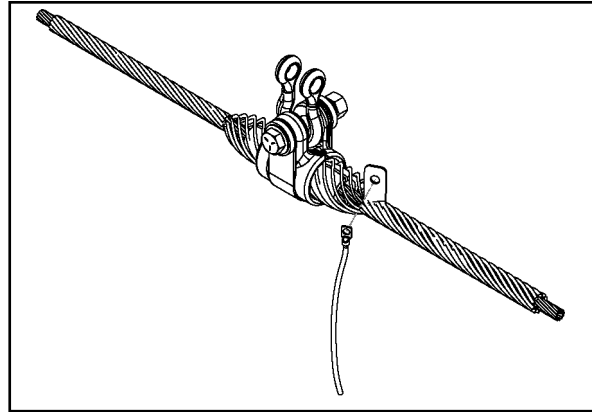

FIGURE 16

SAFETY CONSIDERATIONS

This application procedure is not intended to supersede any company construction or safety standards. This procedure is offered only to illustrate safe application for the individual.

FAILURE TO FOLLOW THESE PROCEDURES MAY RESULT IN PERSONAL INJURY OR DEATH.

This product is intended for a single (one time) use and for the specified application.

Do not reuse or modify this product under any circumstances.

This product is intended for use by trained technicians only. **This product should not be used by anyone who is not familiar with, and not trained to use it.**

When working in the area of energized lines, extra care should be taken to prevent accidental electrical contact.

For proper performance and personal safety, be sure to select the proper size PREFORMED product before application.

PREFORMED products are precision devices. To insure proper performance, they should be stored in cartons under cover and handled carefully.



PREFORMED LINE PRODUCTS

P.O. Box 91129, Cleveland, Ohio 44101 • 440.461.5200 • www.preformed.com • e-mail: inquiries@preformed.com

SP3049