

**FIBERLIGN® UNI-CLOSURE SERIES (6.5", 8", 9.5")
 FOR UNDERGROUND, AERIAL, AND BURIED SPLICES**

Be sure to read and completely understand this procedure before applying product. Be sure to select the proper PREFORMED™ product before application.

CONTENTS	PAGE	CONTENTS	PAGE
1. NOMENCLATURE	2,3,4	12. INSTALL ORGANIZER ASSEMBLY	10
2. DESCRIPTION	4	13. SECURE FIBER IN TRANSITION COMPARTMENT	10,11
3. DETERMINING BLADE SIZE AND LOCK-TAPE™ SEALANT REQUIREMENTS	4,5	14. STORING AND/OR ROUTING FIBERS TO BE SPLICED	11,12
4. END PLATE PREPARATION— CUTTER SET-UP	5	15. STORING AND ROUTING FIBERS	12
5. END PLATE PREPARATION— DRILLING	5,6	16. SPLICE TRAY ARRANGEMENT/STORAGE	12,13
6. END PLATE PREPARATION— LOCK-TAPE™ SEALANT APPLICATION	7	17. TRANSPORT TUBE ROUTING— SPLICE TRAY STORAGE	13
7. CABLE PREPARATION— APPLYING LOCK-TAPE SEALANT FOR FIELD-DRILLED END PLATE	7,8	18. INSTALLING THE SPLICE CASE USING LOCKBAR™ FASTENING	13,14
8. END PLATE ASSEMBLY— CABLES ENTERING THROUGH FIELD- DRILLED HOLES	8,9	19. UNDERGROUND INSTALLATION	14
9. CABLE PREPARATION— APPLYING LOCK-TAPE SEALANT FOR FACTORY- INSTALLED ENTRANCE PORTS	9	20. AERIAL INSTALLATION	14
10. END PLATE ASSEMBLY THROUGH FACTORY-INSTALLED ENTRANCE PORTS	9,10	21. EXTERNAL BONDING PROCEDURE	14,15
11. BONDING AND/OR GROUNDING CABLES WITH METALLIC COMPONENTS	10	22. RE-ENTRY PROCEDURE	15
		23. MAINTENANCE PROCEDURES	15
		24. MEASURING CABLE FOR OLD TYPE POWER END PLATE CUTTER	15,16
		25. SAFETY CONSIDERATIONS	16

1.00 NOMENCLATURE

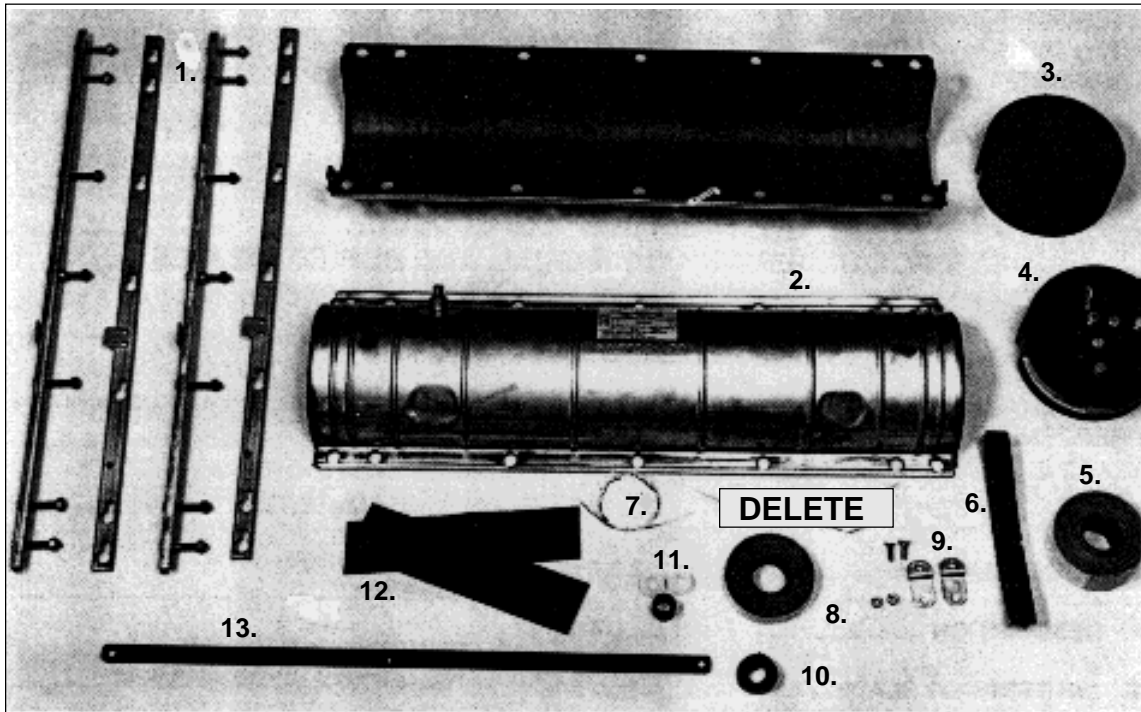
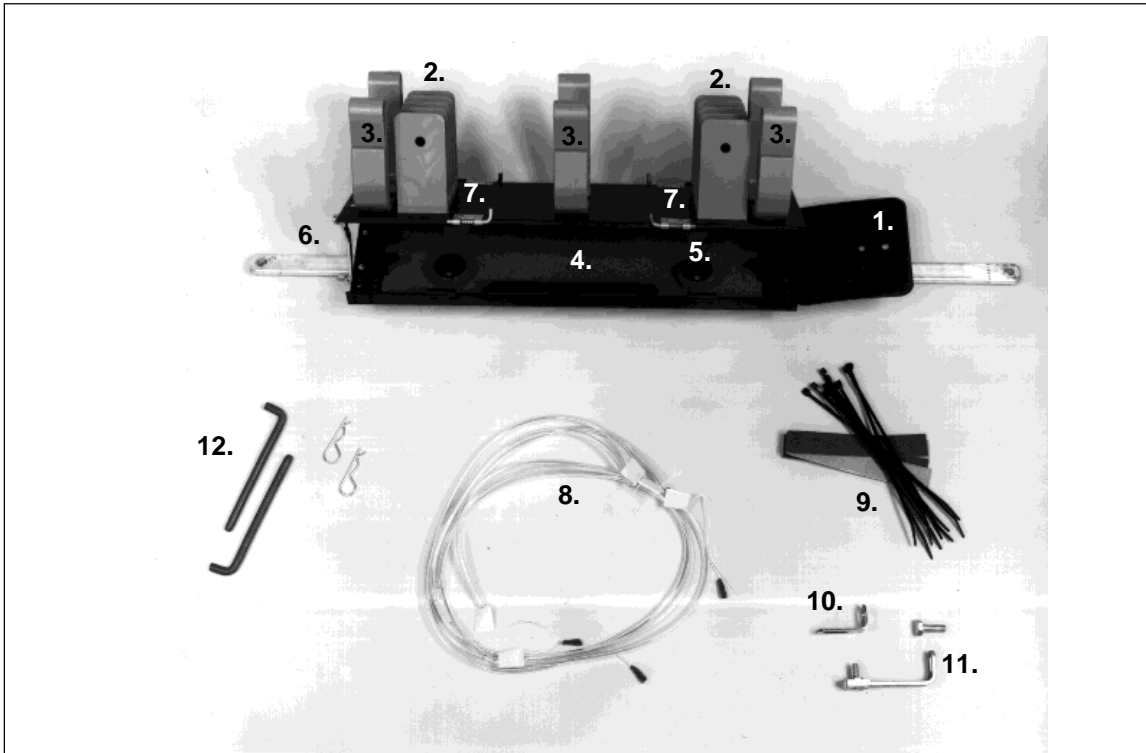

FIGURE 1 – FIBERLIGN® UNI-CLOSURE COMPONENTS

1. LOCKBAR™ Fasteners
2. Stainless Steel Shell Halves
3. Factory-Assembled End Plate
4. Field-Drilled End Plate
5. 1-1/2" LOCK-TAPE™ Sealant
6. Emery Cloth
7. CABLE Mea-SURE™ Tape
8. 3/4" LOCK-TAPE Sealant
9. Aerial Hanging Brackets
10. 1/8" Black Sealant Cord
11. Spacer Adapters
12. LOCK-TAPE Sealant Strips
13. Torque Bar



**FIGURE 2 – STORAGE TRAY AND ORGANIZER
ASSEMBLY COMPONENTS**

1. Unitube Support Tray
2. Splice Tray Retainers
3. Transport Tube Retainer Clips
4. Transition Compartment
5. Retaining Cams
6. Organizer Bar
7. Latches
8. Transport Tubes (8)
9. Ties Wraps, Felt Tape
10. Small "L" Brackets (5) - for 6.5" x 28" UNI-CLOSURE
11. Large "L" Brackets (5) - for 6.5" x 28" UNI-CLOSURE
12. Plastic Pin and Metal Clips

1.01 The FIBERLIGN® UNI-CLOSURE contains everything needed for installation except hand tools, vinyl tape, filled cable cleaning fluid, and C-Cement.

1.02 Tools Needed:

- Splicer’s scissors
- Splicer’s knife
- Tabbing shears
- Common screwdriver
- 1/2" deep well socket
- 3/8" nutdriver or socket
- Needlenose pliers
- Buffer tube removal tool or splitter
- Sidecutters
- Torque Wrench (inch pound readings)*
- Power End Plate Cutter*

*Available from Preformed Line Products

2.00 DESCRIPTION

2.01 For Safety Considerations refer to section 24.00 of this procedure.

2.02 The FIBERLIGN® UNI-CLOSURE organizes and distributes Unitube type fiber optic cables.

2.03 The FIBERLIGN UNI-CLOSURE will accommodate the following splice configurations:

If Unitube Cable is:	Organizer Will Accommodate			
		6.5"	8.0"	9.5"
Continuous Loop (uncut cable)	Ribbon Type	72	144	288
	Single Fiber Unitube Type	96	216	384
	Loose Buffer Tube	96	216	288
Cut Cables	Ribbon Type	144	216	384
	Single Fiber Unitube Type	96	216	384
	Loose Buffer Tube	96	216	384

2.04 The organizer is housed in an enclosed 6.5" x 28", 8.0" x 28", or 9.5" x 28" stainless steel closure.

2.05 The closure is designed for butt-splice application.

2.06 The 6.5" and 8" End Plates will accommodate up to five cable entries in the End Plates provided. Three cable entry locations may be drilled on the lower End Plate seam and will accommodate cable

diameters up to 0.8". The two factory installed cable entrance ports will accommodate cables up to 0.8" in diameter. Other End Plates may be ordered for different configurations or special applications.

The 9.5" End Plate provided will accommodate up to eight 0.8" diameter cable drilled entries.

An alternate End Plate with eight drill locations and four factory installed cable entrance ports will accommodate twelve 0.8" diameter cables.

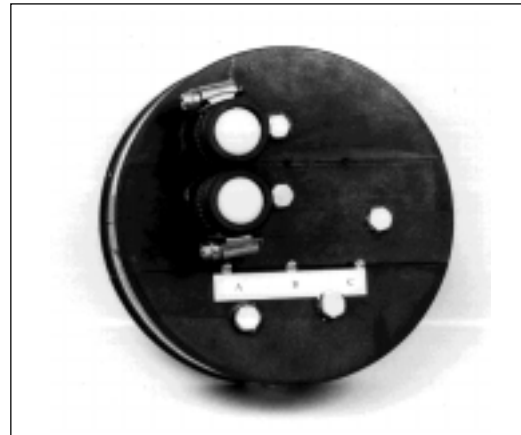

FIGURE 3 - END PLATE CAPACITIES (6.5" END PLATE SHOWN)

3.00 DETERMINING BLADE SIZE AND LOCK-TAPE™ SEALANT REQUIREMENTS

3.01 CABLE Mea-SURE™ Tape is used to determine the correct Power End Plate Cutter blade size and the required layers of LOCK-TAPE™ Sealant.

- 3.02** To use CABLE Mea-SURE Tape:
- Wrap it around the cable tightly.
 - The index line will point to a letter and number.
 - The letter indicates the correct blade size.
 - The number indicates the correct number of layers of half-lapped LOCK-TAPE Sealant.



FIGURE 4 - WRAP CABLE MEA-SURE TAPE AROUND CABLE

NOTE: If the index line falls on a line between two numbers, always use the number to the right of the line.

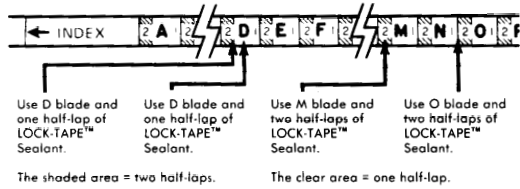

FIGURE 5 - SKETCH OF MEASURE TAPE

CAUTION: Cable may vary in diameter from place to place along its length, so be sure to measure each cable at the area where the End Plate is to be placed.

NOTE: If still using old cutter with Fiber Measure Tape, refer to section 24.00 for instructions.

4.00 END PLATE PREPARATION—CUTTER SET-UP

4.01 When using blades A-D, install the blade directly into chuck. For blades E-DD, first install blade into the drill adapter.

4.02 Secure blade or adapter into drill chuck.

CAUTION: To prevent blades from coming in contact with base of Power End Plate Cutter, insure that blade or adapter is inserted as far into the drill chuck as possible.

4.03 Insert stop-posts in tapped holes in base of cutter corresponding to the 6.5", 8" or 9.5" End Plate diameter and hand tighten firmly. (Figure 6)

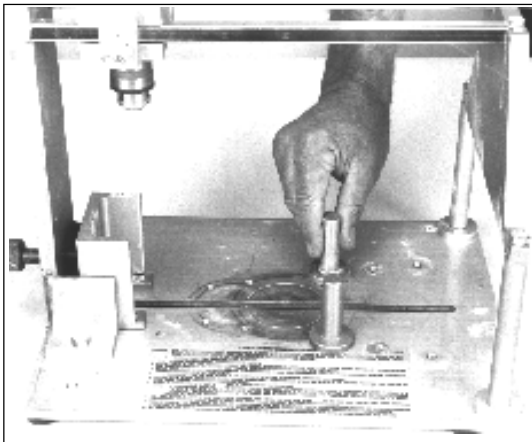

FIGURE 6 - PUT STOP POSTS INTO CUTTER

4.04 When using 6.5" or 8" End Plates with factory installed entry ports, slide the white spacer adapters (provided) over the stop-posts and place the black spacer adapter (provided) at the front edge of the clamp. (Figure 7)

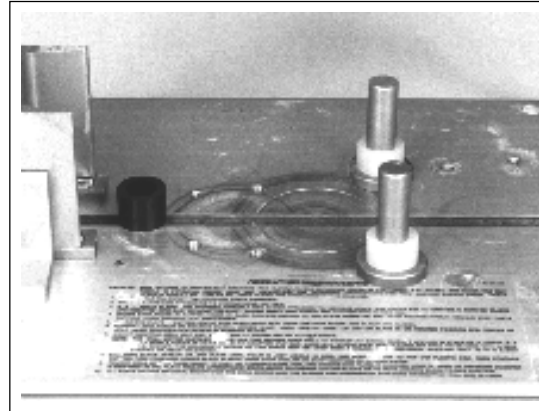

FIGURE 7 - SPACER ADAPTERS FOR 6.5" AND 8" PORTED END PLATES

4.05 For 9.5" End Plate with factory installed entry ports, the End Plate cutter must be modified with Power End Plate Cutter Lift Kit prior to attempting field drilling. (Figure 8)



FIGURE 8 - POWER END PLATE CUTTER LIFT KIT

5.00 END PLATE PREPARATION—DRILLING

5.01 Locate the designated drill marks on the End Plate (A,B,C - 6.5" and 8") (A thru H - 9.5"). These marks should face up when placing End Plate in Power End Plate Cutter. (Figure 9 shows 6.5" End Plate)

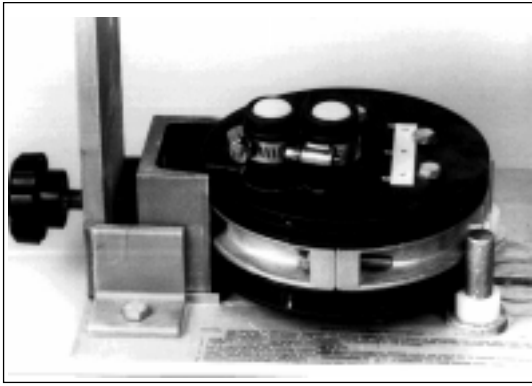

FIGURE 9 - 6.5" END PLATE SHOWING THE DESIGNATED DRILL MARKS

5.02 Cable entry holes on the End Plate seam must be drilled at the designated drill marks on the label.

NOTE: Cables should be placed in End Plate according to the table below.

Placing cables in this manner will facilitate proper routing of fibers within the organizer compartment.

If Cable Is:	End Plate	And Cable Is:	Then Use Holes:
Backbone (Main Cable) Branch (Third Cable)	6.5" & 8.0"	Cut	A & B C
Backbone (Main Cable) Branch (Third Cable)	6.5" & 8.0"	Uncut	A & C B
Backbone (Main Cable) Branches (Third thru Eighth)	9.5"	Cut	A & B C thru H
Backbone (Main Cable) Branches	9.5"	Uncut	A & F B,C,D,E,G,H

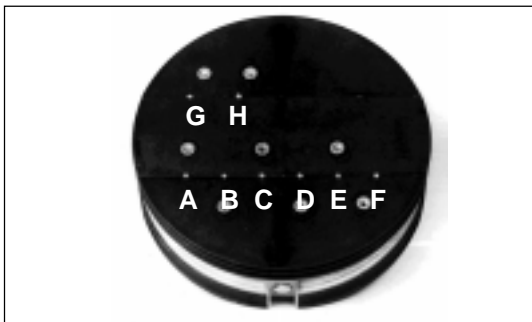

FIGURE 10 - DRILL MARK POSITIONS, A-H (9.5" PLATE SHOWN)

5.03 To position End Plate in the cutter:

- Rotate End Plate and slide bearing block along the guides until the drill is positioned over designated drill marks.
- Then, tighten the clamp screw and thumb screws on the bearing block. (Figure 11)

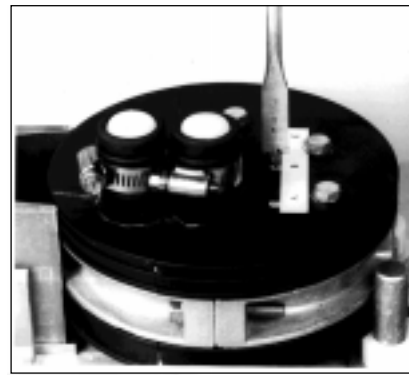

FIGURE 11 - BLADE POSITIONED

CAUTION: The thumb screws in the bearing block are backed up by a small nylon pellet. Using cutter with pellet missing could cause damage to the guide rails. To prevent damage, remove the thumb screws and insert a small piece of cable sheath. Additional nylon pellets are available from PLP.

5.04 Mount a 3/8" drill, drill blade adapter, and 1/2" deep well socket to the upper end of the bearing block shaft.

5.05 Drill through the End Plate until the drill shaft bottoms out on the stop collar. **When the drill has bottomed out, stop the drill. Do not** bring the blade back up while it is still turning.

5.06 If additional holes are needed, repeat preceding steps 4.00-5.05

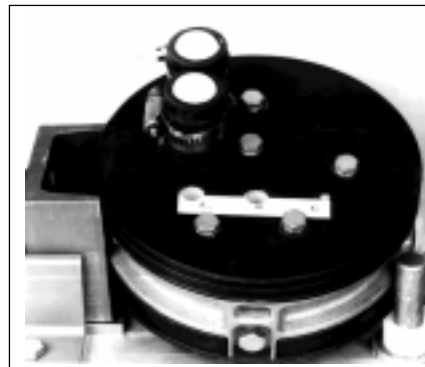

FIGURE 12 - END PLATE WITH HOLES DRILLED (6.5" PLATE SHOWN)

5.07 Remove the End Plate from the cutter and disassemble End Plates by removing both bolts.

6.00 END PLATE PREPARATION— LOCK-TAPE™ SEALANT APPLICATION

- 6.01 Remove sharp edges on plastic and foam in area of opening with emery cloth (provided).

**SCUFF LIGHTLY.
DO NOT REMOVE TOO MUCH MATERIAL**

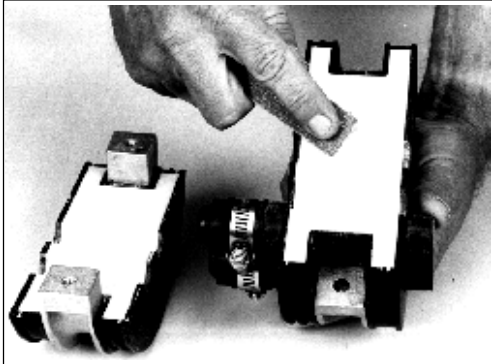

FIGURE 13 - SCUFFING CABLE OPENINGS

- 6.02 Apply a thin coat of C-Cement to each inside surface of the End Plate sections.
- 6.03 When C-Cement becomes tacky, remove protective backing from a strip of LOCK-TAPE Sealant.

PLP TIP: Use removed backing from a LOCK-TAPE Strip to help dry the C-Cement applied to the End Plate. (Figure 14)

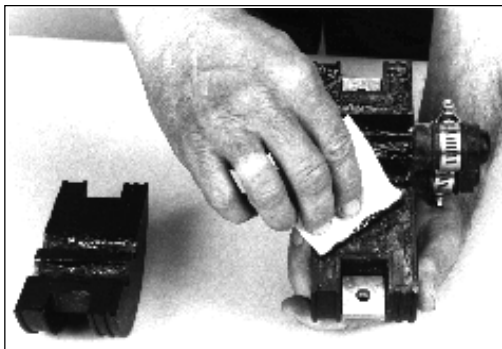

FIGURE 14 - C-CEMENT ON END PLATE

- 6.04 Without stretching, apply LOCK-TAPE™ Sealant over prepared surface of the End Plates, following the contour of the cable holes.

Allow approximately 3/4" of LOCK-TAPE Sealant to extend beyond each end of the End Plate. This will serve as a tightening indicator during the End Plate assembly.

- 6.05 Square cut the tape away from the bolt holes. (area just beyond the metal insert.) (Figure 15)

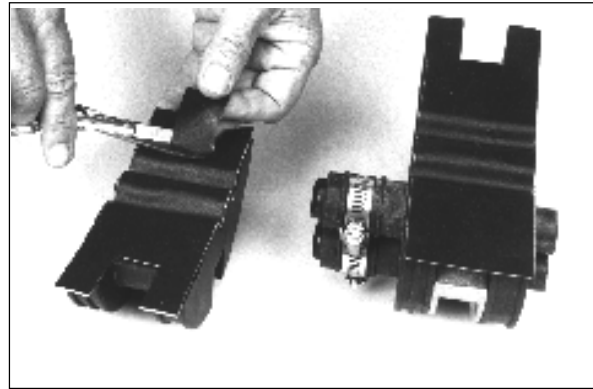

FIGURE 15 - SQUARE CUT BOLT HOLES

7.00 CABLE PREPARATION— APPLYING LOCK-TAPE SEALANT FOR FIELD-DRILLED END PLATE

- 7.01 Measure and mark for sheath openings:

6.5"
- 260" continuous length cables
- 130" cut cables

8.0"
- 264" continuous length cables
- 132" cut cables

9.5"
- 274" continuous length cables
- 137" cut cables

- 7.02 Make additional marks on the cable according to the table below. Using the emery cloth provided, scuff the cable between the marks for cables with metallic components or up to the marks for dielectric cables. Always scuff around the cable, never scuff lengthwise.

Closure Size	For cables with metallic components, mark cable outward from cable opening:	For dielectric cables, mark cable outward from cable opening:
6.5"	1.5" & 5.5"	4"
8"	1.5" & 5.5"	4"
9.5"	1.5" & 6"	4.5"

- 7.03 Coat the scuffed area of cable with C-Cement and allow to dry to tacky base.

7.04 Apply required number of half-lapped layers of 3/4" LOCK-TAPE™ Sealant around the cable in the area coated with C-cement. Stretch tape while applying. (Figure 16)

PLP TIP: Stretch tape enough to reduce its width to 1/2". Figure 17 shows the completed application of one half-lapped layer of LOCK-TAPE Sealant.

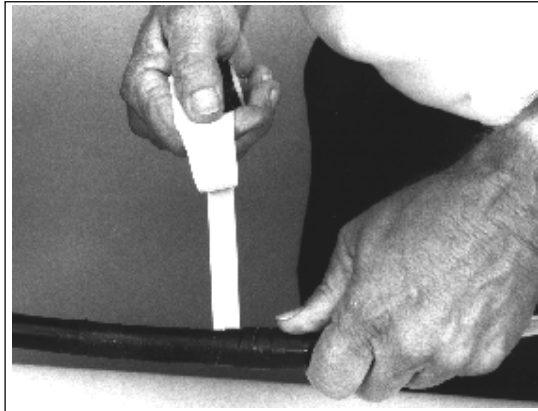

FIGURE 16 - APPLYING LOCK-TAPE

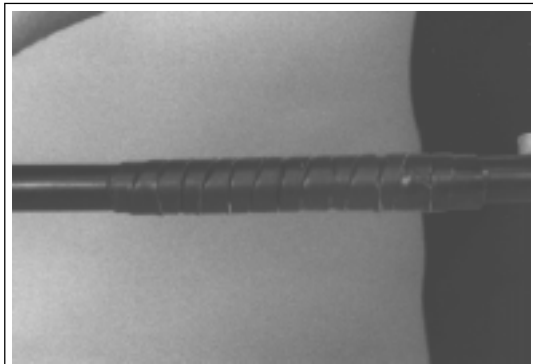

FIGURE 17 - COMPLETED LOCK-TAPE SEALANT

7.05 Apply a layer of vinyl tape to protect LOCK-TAPE Sealant. This will be removed during End Plate assembly.

7.06 Remove the cable sheath to the opening mark(s). Remove any other coverings to expose the Unitube in the center of the cable.

7.07 If cable contains metallic components, remove an additional 1/2" of outer sheath exposing the turn-plate. This is preparation for bonding and grounding.

7.08 Remove moisture block tape and any other materials from exposed tube.

8.00 END PLATE ASSEMBLY—CABLES ENTERING THROUGH FIELD-DRILLED HOLES

8.01 Using the hex bolts provided, fasten the "L" bracket and retaining clip to the End Plate.

8.02 Before installing prepared cables into the End Plate halves, apply 1/4" wide bead of C-Cement adjacent to the drilled hole. (Figure 18)

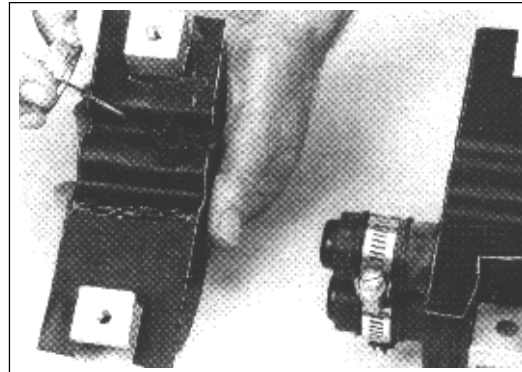

FIGURE 18 - BRUSH C-CEMENT OVER LOCK-TAPE SEALANT

NOTE: If cables being placed in End Plates require bonding and/or grounding, review Section 11.00 before installing End Plate.

8.03 Position prepared cables into the lower End Plate section, allowing 1/2" of the LOCK-TAPE Sealant to extend beyond the inside of the End Plate. THIS IS A CRITICAL MEASUREMENT.

8.04 For cables containing non-metallic strength members, measure required length for attachment by placing the strength members adjacent to the "L" bracket (with retainer cap removed) and cutting them 1/16" to 1/8" less than the "L" bracket.

8.05 Apply the upper End Plate section and insert End Plate bolts.

8.06 Using a 1/2" socket and ratchet, tighten each bolt evenly in rotation 2 or 3 turns at a time.

CAUTION: Do not use power tools for this operation.

8.07 While tightening, the excess LOCK-TAPE Sealant extending from the End Plate section will fold back. When the LOCK-TAPE Sealant stops moving (folds back), the bolts are sufficiently tight. (Figure 19)

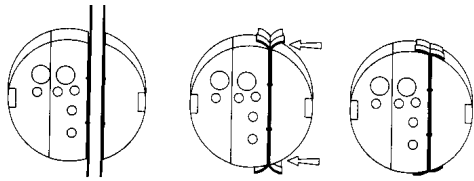

FIGURE 19 -TAPE FOLDING BACK

CAUTION: DO NOT OVER TIGHTEN.

8.08 Trim excess LOCK-TAPE™ Sealant to within 1/8" of End Plate. **DO NOT STRETCH TAPE DURING TRIMMING PROCESS.**

8.09 Apply vinyl tape to exposed LOCK-TAPE Sealant on the cable.

**9.00 CABLE PREPARATION—
APPLYING LOCK-TAPE SEALANT
FOR FACTORY INSTALLED
ENTRANCE PORTS**

9.01 Measure and mark the cable to remove 130" of sheath.

9.02 Remove the cable sheath to the opening mark(s). Remove any other coverings to expose the Unitube in the center of the cable.

9.03 Remove moisture block tape and any other materials from exposed tube.

9.04 Mark the cable according to the table below. Using the emery cloth provided, scuff the cable between the marks. Always scuff around the cable never scuff lengthwise.

Closure Size	For cables with metallic components, mark cable outward from cable opening:	For dielectric cables, mark cable outward from cable opening:
6.5"	5" & 6.5"	3.5" & 5"
8"	5" & 6.5"	3.5" & 5"
9.5"	5" & 7"	3.5" & 5.5"

9.05 Coat the scuffed area of cable with C-Cement and allow to dry to tacky base.

9.06 Cut the end of the 1-1/2" LOCK-TAPE Sealant at a 45-degree angle, and position it (white side down) on the C-Cement coating.

9.07 Stretch the LOCK-TAPE Sealant slightly while wrapping it around to form a collar. Wrap the LOCK-TAPE Sealant until the collar is slightly larger than the inner diameter of the neoprene boot on the outside of the factory installed entrance port. (Figure 20)

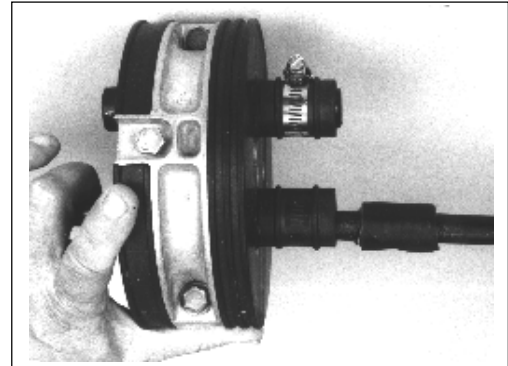

FIGURE 20 - COMPLETED LOCK-TAPE™ COLLAR

9.08 Apply one layer of 1/8" Black Sealant Cord on the side that will be inserted into the End Plate at the junction of the LOCK-TAPE Collar and cable sheath.

PLP TIP: Coating the collar with C-cement eases the entrance of collar into port and also provides a better seal.

9.09 **DO NOT INSTALL ANY BONDING CONNECTORS TO THE CABLE AT THIS TIME.**

**10.00 END PLATE ASSEMBLY
THROUGH FACTORY-INSTALLED
ENTRANCE PORTS**

10.01 Choose the port through which the cable will enter the splice closure.

NOTE: For the ease of future cable entry, use the bottom port for the first cable entry.

10.02 Loosen the hose clamp and remove the plug from within the port.

10.03 Using a sheath knife cut the neoprene nipple flush with the inside surface of the End Plate.

10.04 Insert cable into the entrance port.

10.05 If the cable contains metallic components, push it through the port until 2" of the cable sheath extends beyond the port. Remove 1/2" of sheath and expose the metal shield. For all dielectric cables, the cable sheath should extend 1/2". THIS IS A CRITICAL MEASUREMENT. (Figure 21)



FIGURE 21 - SHEATH EXTENDING BEYOND THE PORT

10.06 Tighten the hose clamp to secure cable.

11.00 BONDING AND/OR GROUNDING CABLES WITH METALLIC COMPONENTS

NOTE: Installation of bonding and grounding components may be easier if installed prior to placing cables into End Plate (FIELD-DRILLED HOLES ONLY.)

11.01 If cable contains a metallic shield (turn plate), install shield connector and/or bonding assembly per company specifications.

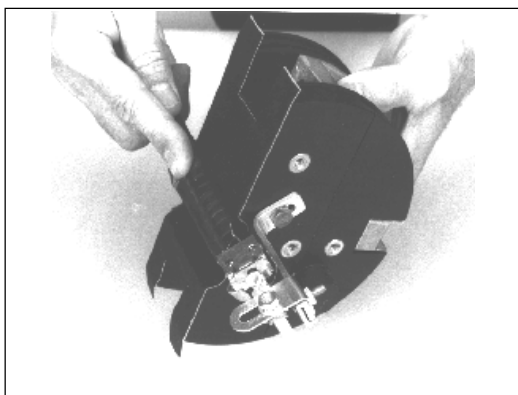

FIGURE 22 - AT&T BONDING ASSEMBLY

11.02 Use one of the small "L" shaped brackets and attach shield connector and/or bonding assembly to the retainer clip.

NOTE: Hose clamp on the entrance port on the outside of the end plate may be loosened during this process.

11.03 For cables containing a strength member, measure required length for attachment by placing the strength members adjacent to the "L" bracket (with retainer cap removed) and cutting them 1/16" to 1/8" less than the "L" bracket.

12.00 INSTALL ORGANIZER ASSEMBLY

12.01 Position the Organizer Assembly with the Uni-tube Support Plate closest to the End Plate containing the cables.

12.02 Remove the torque bar attachment bolt from the End Plate and secure the organizer bar to the End Plate. (Figure 23)

12.03 Attach the opposite end of the organizer bar to the factory-assembled End Plate.

CAUTION: Use care not to damage fibers while positioning organizer assembly.

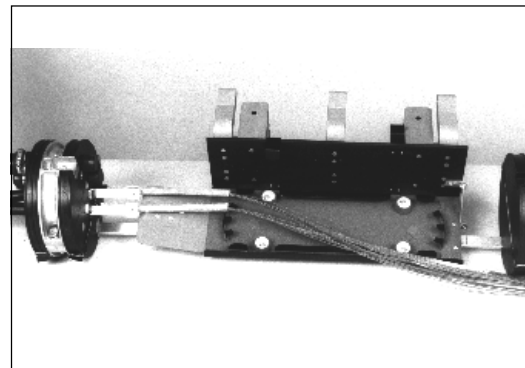

FIGURE 23 - ORGANIZER BAR TO END PLATE

13.00 SECURE FIBER IN TRANSITION COMPARTMENT

13.01 Hinge organizer assembly open. Lock organizer assembly in the open position.

NOTE: To open organizer loosen the wing nut at the bottom right side of assembly and release the two (2) latches located in the front of the organizer assembly. Be sure hinged arm is completely engaged in locked position. Retighten wing nut.

13.02 The Unitube length required from the End Plate to the transition compartment follows. Begin measurement from the edge of the End Plate and mark Unitube.

<u>Closure Size:</u>	<u>Mark at:</u>
6.5"	8"
8"	7-3/4"
9.5"	6"

13.03 Remove the Unitube to the mark and thoroughly clean the fibers using company approved methods.

NOTE: Prior to installing Unitube in Transition Compartment, apply Moisture Blocking Sealant into the end of the Unitube according to company or manufacturer's practices.

13.04 Thoroughly clean the Unitube for the first 2" from the fiber. Wrap two (2) layers of felt tape around the Unitube as shown in Figure 24.

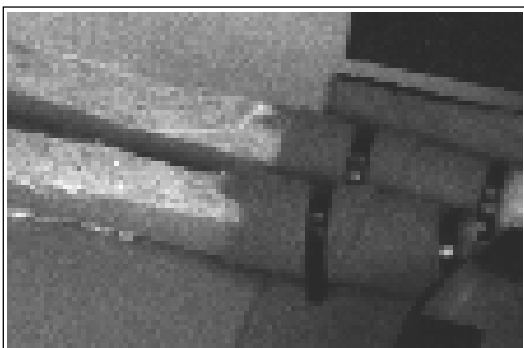

FIGURE 24 - WRAP FELT TAPE AROUND UNITUBE

CAUTION: USE CARE WHEN HANDLING EXPOSED FIBER.

13.05 For continuous (expressed) length cables, use the tie wraps provided to secure the two (2) main cables to the top and bottom of the transition compartment.

13.06 If a third cable (branch cable) is used secure the Unitube to one of the outside tie wrap locations.

13.07 For cut cables use the tie wraps provided to secure the two (2) main cables to the inside tie wrap locations. (Figure 24)

13.08 If a third cable (branch cable) is used secure the Unitube to one of the middle holes.

14.00 STORING AND/OR ROUTING FIBERS TO BE SPLICED

14.01 Fibers may be installed into transport tube using pull string contained within the tube; however, for small count fiber groups, it may be easier to push fiber through the tube.

14.02 Identify and cut fibers to be spliced at the midpoint in the fiber loop. This will permit splicing in either direction.

14.03 Group fibers into groups of 12 or 18, based on quantity of fibers to be spliced. This will identify the number of required transport tubes.

14.04 Select the required number of transport tubes, and wrap one layer of felt tape 1/2" from both ends of the tube.

14.05 To feed the fiber through the transport tube, apply the pull string to the fiber with a double half hitch knot. (Figure 25)

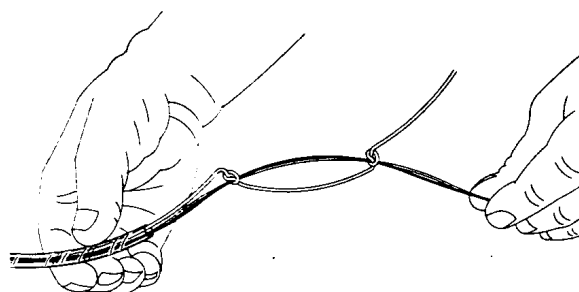

FIGURE 25 - FEED FIBER THROUGH TRANSPORT TUBE

14.06 Gently pull the fiber group through the transport tube. (Figure 26)

PLP TIP: The fiber group will feed through the transport tube easier if the transport tube is held as straight as possible during the operation.

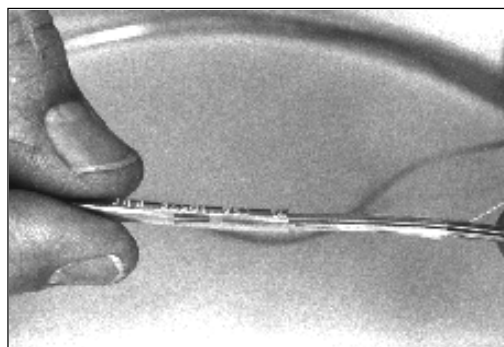

FIGURE 26 - FIBER THROUGH TRANSPORT TUBE

14.07 Complete Steps 14.04 through 14.06 for the remaining fiber groups.

14.08 Route transport tubes under hinge locking arm and secure with tie wraps. (Figure 27)

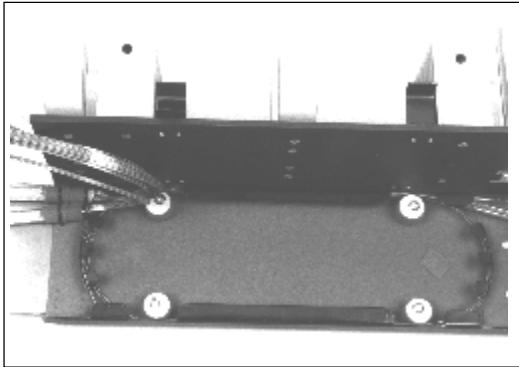

FIGURE 27 - ROUTE FIBERS AROUND COMPARTMENT

14.09 Using the tie wraps provided, secure all the transport tubes to the inside tie wrap locations. (Figure 28)

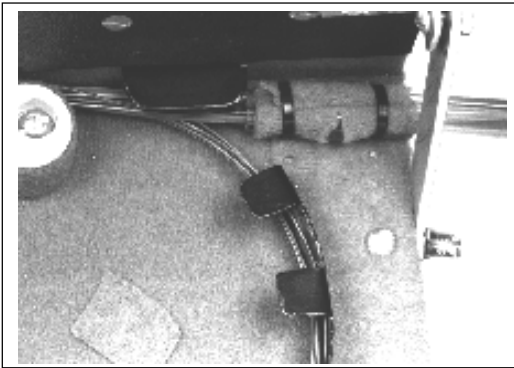

FIGURE 28 - SECURE TRANSPORT TUBES

15.00 STORING AND ROUTING FIBERS

15.01 Loosen the four fiber retaining cams located in the four corners of the transition compartment. Rotate cam to the open position. (Maximum distance between cam and inside edge of transition compartment.)

CAUTION: To avoid signal attenuation, care should be taken when routing ribbon fiber. Ribbon should be positioned in front of each other around transition compartment. Avoid crossing over or twisting ribbons.

15.02 Route fibers one and one-half times around the transition compartment and out under the hinge for cut fiber. For continuous loop, wrap until all fiber is stored.

15.03 Rotate fiber retaining cams until fibers are "gently" pressed between the cam and transition compartment edge.

CAUTION: To avoid signal attenuation do not rotate cams to a position that would exert pressure on the fibers.

15.04 Secure (tighten) screws on fiber retaining cams.

15.05 Close and secure organizer assembly.

16.00 SPLICE TRAY ARRANGEMENT/STORAGE

16.01 Select the transport tubes containing fibers to be spliced.

16.02 Unsnap and remove the Splice Tray cover.

16.03 Locate the transport tube entry point in the top left-hand corner of the Splice Tray. Fibers will enter Splice Tray at this point.

16.04 Place tie wraps through the holes.

16.05 Position the transport tube into the tray so the felt tape lies within the tie wraps. Secure each transport tube in two locations using the tie wraps.

16.06 Select the fibers from one direction and route them around the tray (under the edge) until the fibers have made one-and-one-quarter laps in the tray. (Figure 29)

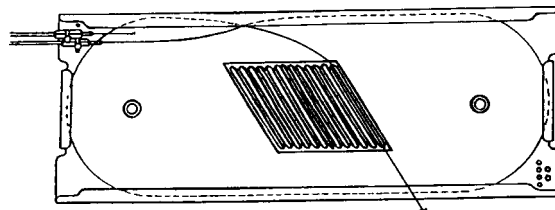

FIGURE 29 - ROUTE FIBERS

16.07 Select the fibers from the opposite direction and route them around the tray until the fibers have made one-and-three quarters of a lap. (Figure 30)

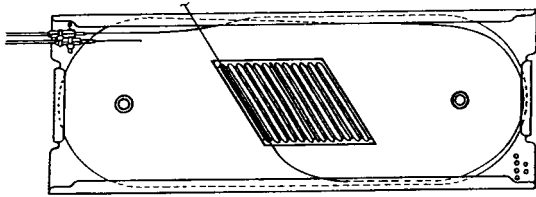

FIGURE 30 - ROUTE FROM OPPOSITE DIRECTION

- 16.08** Splice the fibers according to your accepted company practices.
- 16.09** Snap on the tray cover.
- 16.10** Complete Steps 16.01 through 16.07 for the remaining transport tubes.

**17.00 TRANSPORT TUBE ROUTING—
SPLICE TRAY STORAGE**

- 17.01** Remove the two plastic pins and metal pin clips from the Splice Tray Retainers.
- 17.02** Route the transport tubes from the rear of the transition compartment through the three (3) front transport tube retainer clips.
- 17.03** Install splice trays into their appropriate location in the Splice Tray Retainers. (Figure 31)

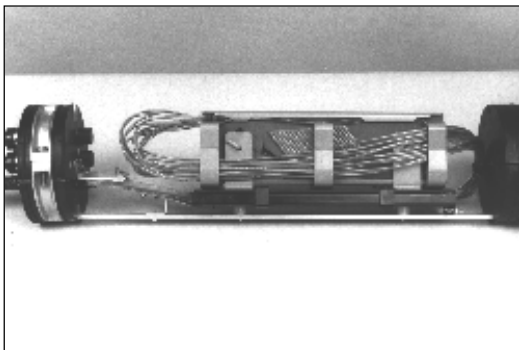

FIGURE 31 - INSTALLING TRAYS

- 17.04** Re-insert Splice Tray plastic pins and metal pin clips to secure the Splice Trays in the Organizer Assembly.

**18.00 INSTALLING THE SPLICE CASE
USING LOCKBAR™ FASTENING**

18.01 The neoprene in the outer shells must be pliable when installed. In cold weather, for new installation or re-entry, warm outer shells prior to installation. Remove protective paper liners.

PLP TIP: Shells may be warmed in a truck cab or by placing near manhole vent hose. If space permits, bring the shells down into the manhole during splicing operation.

18.02 Aerial applications require that the suspension plates be installed to the back LOCKBAR Fastener prior to its application to the Splice Case. Special holes are provided on either side of the back LOCKBAR Fastening Assembly for this purpose. (Figure 32)

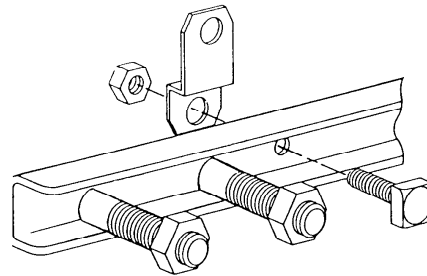

FIGURE 32- AERIAL SUSPENSION PLATES

18.03 For external bonding, the bolt, bonding clip, and nut must be applied to the front (keyhole) LOCKBAR Assembly before mating it with the back LOCKBAR Assembly. Special holes are provided on either side of the front LOCKBAR Assembly for this purpose. The bolt head is applied inside the LOCKBAR Channel. The bonding clip and nut are applied to the bolt on the outside LOCKBAR Assembly face. Refer to Figure 33 for proper alignment of parts.

NOTE: The external bonding clamp **must** be used for all aerial, buried, and underground installations.

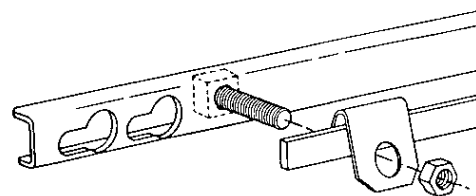

FIGURE 33- PROPER ALIGNMENT OF PARTS

18.04 Now that all LOCKBAR System preparatory steps have been accomplished, apply the back shell half (without air flange) over End Plates. (Figure 34)

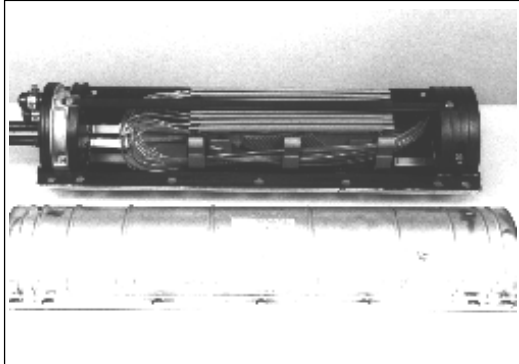

FIGURE 34 - APPLYING BACK SHELL

18.05 Apply the front shell half (containing air flange).

18.06 NOTE: Prior to the application of the back LOCKBAR Assembly, be certain that the nuts are near the end of the threaded bolts. The ends of the threaded bolts have been treated so that the nuts remain on them and cannot be easily removed.

NOTE: Positioning tabs have been added to each LOCKBAR Fastener (front and back). These tabs should always point away from the Splice Case and will help assure proper alignment and eliminate the chance of a bar being misapplied. (Figure 34)

18.07 Install LOCKBAR Fastening system as shown in Figure 35. LOCKBAR Fastening consists of a (back) studded LOCKBAR Assembly with factory assembled threaded bolts and nuts, and a (front) key-hole LOCKBAR Assembly. The back LOCKBAR Assembly mates with the front LOCKBAR Assembly through the flange of the Splice Case shells, and then locks into position.

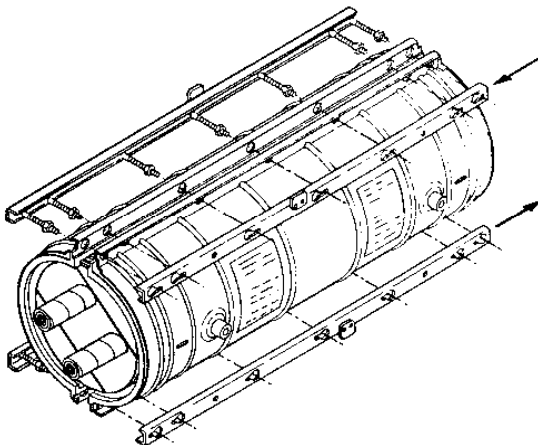

FIGURE 35 - LOCKBAR™ FASTENING

18.08 Tighten LOCKBAR Fastener in accordance with torque sequence label located on the front half of Splice Case.

19.00 UNDERGROUND INSTALLATION

19.01 The Splice Case should be installed between the manhole racks.

19.02 PREFORMED™ Splice Cases are very light and will float in a water-filled manhole. They must be tied down.

NOTE: It is recommended that the PREFORMED™ Splice Case Manhole Support (Cat. #80007614) be used to support and tie down the Splice Case.

20.00 AERIAL INSTALLATION

20.01 Place 2 lashing wire clamps (not supplied) on the suspension strand (see Figure 36). One directly above each aerial suspension plate that was placed in Step 18.02.

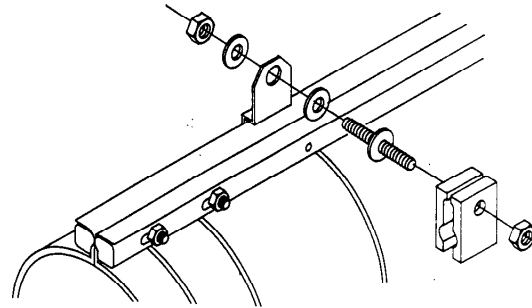

FIGURE 36 - AERIAL INSTALLATION

20.02 Be sure all nuts and washers are in their proper position. Tighten nuts securely.

21.00 EXTERNAL BONDING PROCEDURE

External bond methods will be shown, but company practice should be followed.

21.01 Select the external bonding clamp and bonding bolt from the package.

21.02 Loosely bolt the bonding clamp to one of the threaded inserts in the bottom section of the End Plate where the cables were installed. Install a length of bonding ribbon (not supplied) from the bonding clamp on the LOCKBAR System to the bonding clamp on the End Plate. Securely tighten the bolt on the End Plate. (Figure 37)

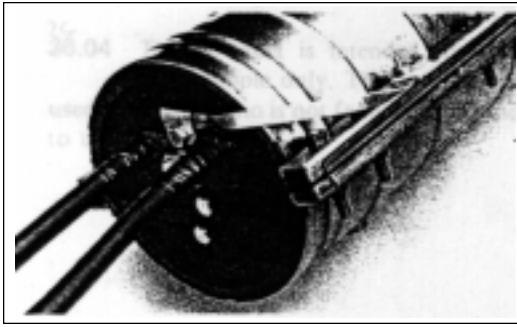

FIGURE 37 - BONDING CLAMP

21.03 For manhole installations, extend a length of bonding ribbon from the bond clamp on the LOCKBAR Assembly to the bonding and grounding harness of the manhole. Securely tighten all connections.

21.04 For direct buried installations, extend a length of bonding ribbon (not supplied) from the bonding clamp on the LOCKBAR Assembly to a ground rod. Securely tighten all connections.

21.05 For aerial installations, the case is bonded to the suspension strand through the suspension plate assembly. Securely tighten all connections.

NOTE: If all-dielectric cable was used, Steps 21.03 through 21.05 must be followed in all installations.

21.06 If cable contains metallic components, all cables must be bonded together. Remove bolt from threaded inserts on outside of End Plate, install continuous length of bonding ribbon through bonding clips and secure to End Plate with the End Plate bolts.

22.00 RE-ENTRY PROCEDURE

22.01 Loosen the nut on the external bonding clamp and remove bonding ribbon(s).

22.02 Loosen the nuts on the LOCKBAR System to allow removal of the LOCKBAR Assemblies.

NOTE: Do not unscrew nuts beyond the treated area. **DO NOT USE AIR WRENCHES** for this operation.

22.03 Remove the case halves.

22.04 If new cables are to be added, a new End Plate must be used. Remove all old sealing or LOCK-TAPE Sealant from the cables. Install new End Plate using the appropriate steps in this procedure.

23.00 MAINTENANCE PROCEDURES

23.01 The PREFORMED Splice Case is designed for numerous re-entries. However, certain precautions must be taken prior to re-application.

23.02 Be sure to clean shells and End Plates thoroughly, to remove sand, dirt and other foreign substances.

23.03 Any bent studs or stripped nuts should be replaced. Only use hardware supplied by Preformed Line Products.

23.04 The shells should be lubricated prior to re-application. A uniform thin layer is all that is necessary. Only use lubrication supplied by Preformed Line Products (Catalog No. 80801566).

23.05 Any shells that are bent or distorted should not be used.

23.06 Prior to re-installation, the neoprene on the shells should be allowed to return to its original state. Warming the shells speeds up the process.

24.00 MEASURE CABLE FOR OLD TYPE POWER END PLATE CUTTER

24.01 Measure each cable at the location the End Plates will be applied using the Fiber Optic Measure Tape.

24.02 To use the Fiber Optic Measure Tape, hold the tape so the index line is facing you. Then wrap the tape around the cable tightly to obtain the reference number. (Figure 38)

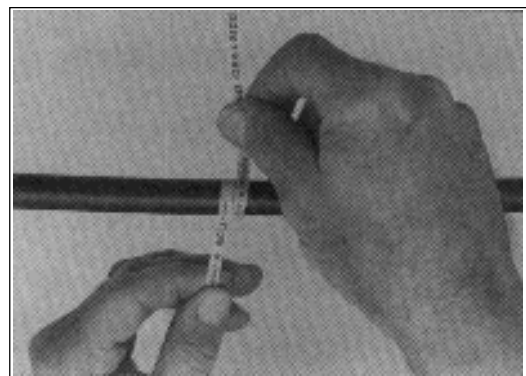

FIGURE 38 - MEASURING WITH FIBER OPTIC MEASURE TAPE

If the index line falls on a line between two numbers, always use the number to the right of the line. (Figure 39)

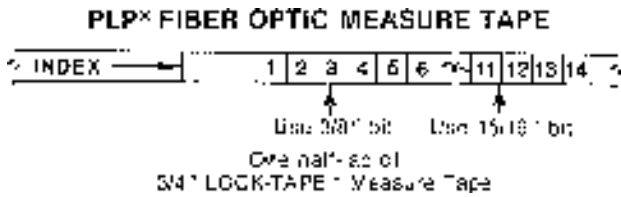

FIGURE 39 - FIBER OPTIC MEASURE TAPE

Once you have obtained the cable diameter reference number, use the blade size table to the right of the tape and locate that number. This will indicate the blade size to be used to drill the hole in the End Plate.

PLP TIP: Cable will vary in diameter from place to place along its length, so be sure to measure each cable at the area where the End Plate is to be placed.

25.00 SAFETY CONSIDERATIONS

25.01 This application procedure is not intended to supersede any company construction or safety standards. This procedure is offered only to illustrate safe application for the individual. Failure to follow these procedures may result in personal injury.

25.02 When working in the are of energized lines, extra care should be taken to prevent accidental electrical contact.

25.03 For proper performance and personal safety, be sure to select the proper size PREFORMED™ Product before application.

25.04 This product is intended for use by trained craftspeople only. This product **should not be used** by anyone who is not familiar with, and not trained to use it.

PREFORMED LINE PRODUCTS 

P.O. Box 91129, Cleveland, Ohio 44101 • 440.461.5200 • www.preformed.com • e-mail: inquiries@preformed.com

SP2772-1