

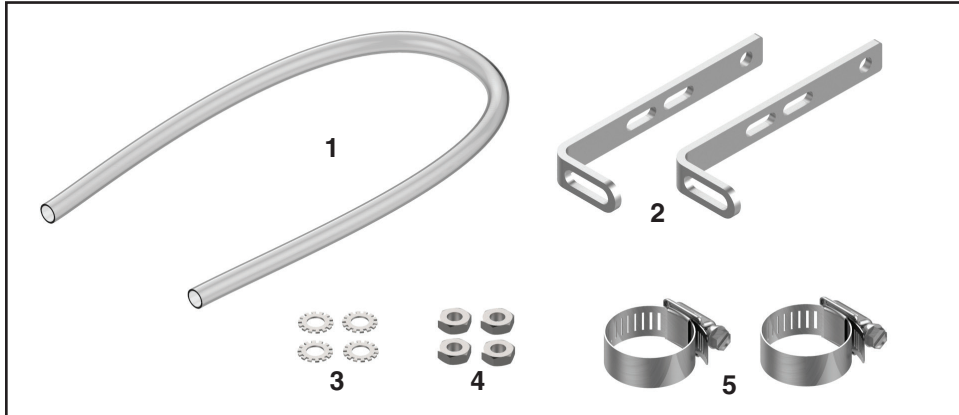

COYOTE® Micro Cable and Duct Restraint Kit for COYOTE® Dome Closures

Be sure to read and completely understand this procedure before applying product. Be sure to select the proper PREFORMED™ product before application. When installing Micro Cable in these closures, the following steps must be followed to safeguard the extremely thin sheath used for these cables.



NOMENCLATURE

1. Protective Tubing (1)
2. L-Retention Bracket (2)
3. Lock Washers (4)
4. 1/4" - 20 Hex Nut (4)
5. Hose Clamps (2)

Step #1 Measure the diameter of the micro cable to determine the appropriate grommet to use and insert the cable through the grommet.

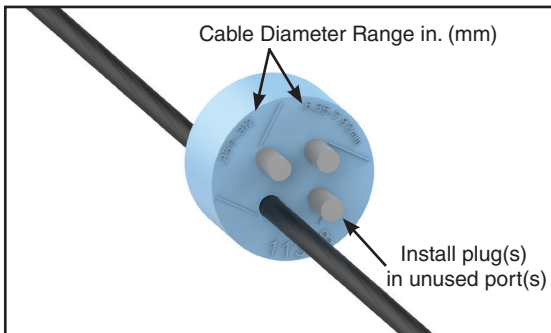
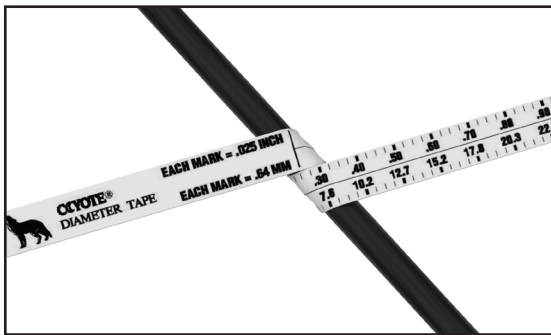

Step #2 Slide the grommet along the micro cable until it is against the end of the micro duct as shown below. **IMPORTANT NOTE: Make sure that the micro duct is NOT inserted into the grommet. The micro duct opening must be located outside of the closure to prevent any possible water migration into the closure through the micro duct.**

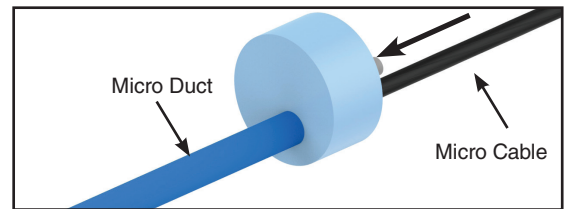

Step #3 Mark the cable a minimum of 2" (51 mm) from the inner surface of the grommet and remove the cable sheath from the micro cable according to the instructions given in the closure application procedure.

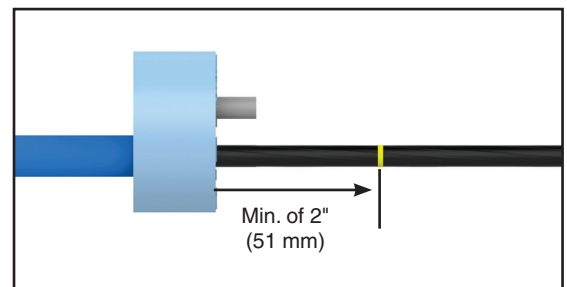

Step #4 Cut off a 1" (25 mm) piece of tubing and slit it as shown below.

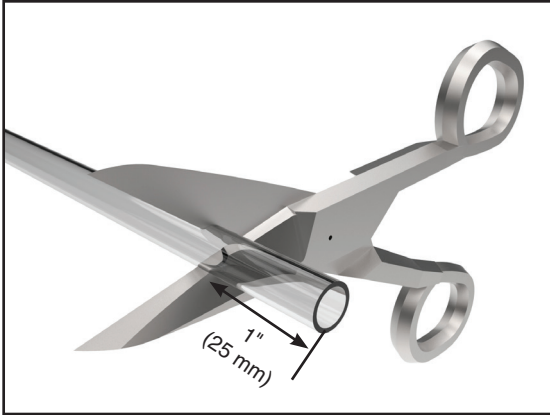

Step #5 Place the 1" (25 mm) piece of tubing over the cable sheath of the micro cable and align the end of the tubing with the cable sheath opening as shown below.

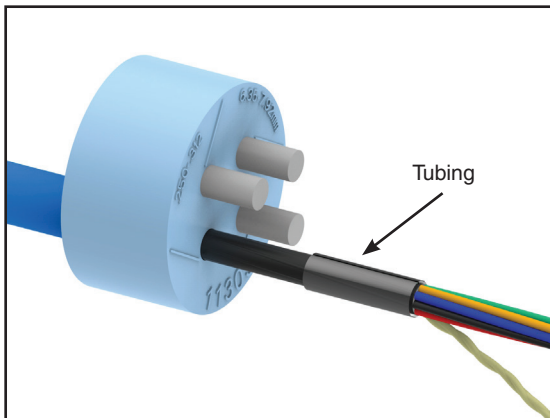

Step #6 Trim the cable strength member 1-3/8" (35 mm) from the cable sheath opening for short strength member brackets and 2-3/4" (70 mm) from the cable sheath opening for long strength member brackets.

For Short Strength Member Brackets

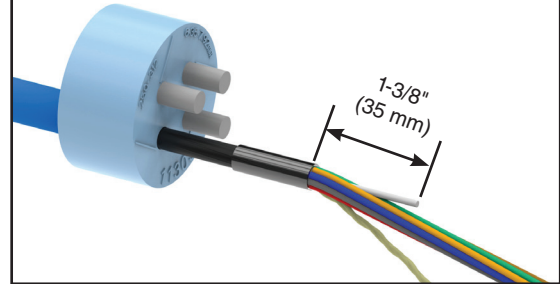

For Long Strength Member Brackets

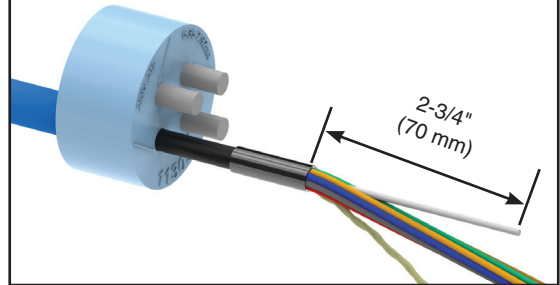

Step #7 Secure the cable strength member under the cap of the strength member bracket, (included in closure kit). If the cable contains aramid yarn, braid it and wrap it around the stud underneath the cap before securing the strength member.

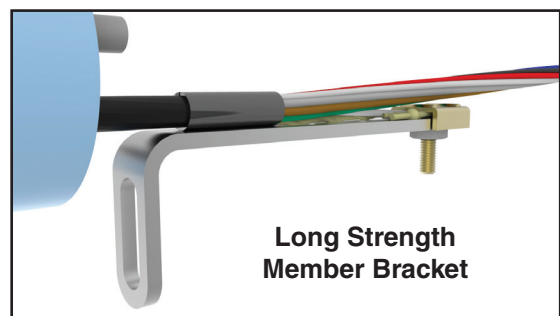
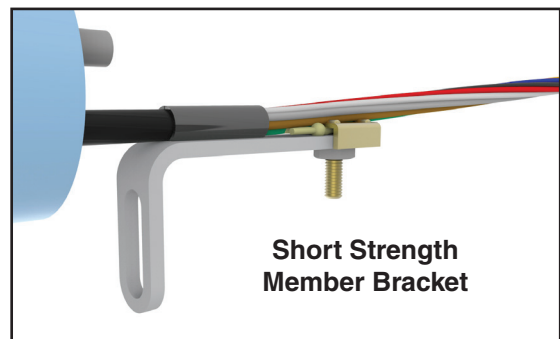

Step #8 Position the tubing on the cable so that the slit in the tubing is facing away from the strength member bracket. Secure the cable to the strength member bracket with a hose clamp in the area where the tubing is positioned.

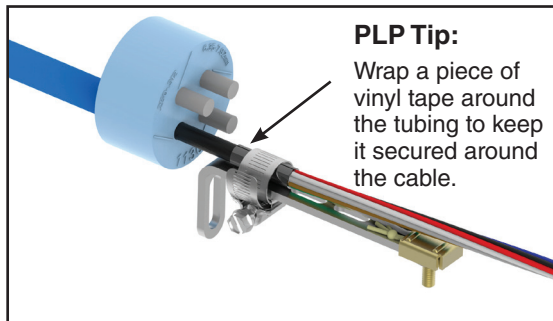

Step #9 Lubricate the grommet and position it into the grommet pocket of the end plate according to the closure application procedure. Position the slot of the strength member bracket leg over the stud. Push the cable back through the grommet and the micro duct to install the strength member bracket onto the stud of the end plate.



Step #10 Install the lock washer and nut against the bracket, (included in closure kit) but do not tighten fully, so that the bracket can slide as the grommet is secured.



Step #11 Install the cable cap and secure it with the hex bolts.

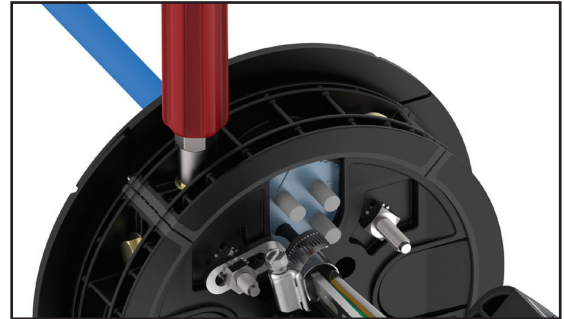

NOTES:

- Tighten bolts by hand evenly until cable cap is fully seated (DO NOT USE POWER TOOLS TO TIGHTEN BOLTS).
 - When using a can wrench or nut driver, the installed torque is 35 to 40 in-lbs.
 - TIGHTEN ALL UNUSED CABLE CAPS.
- IMPORTANT:** Tighten down the strength member bracket after the caps are tightened.

Step #12 On the outside of the end plate, install a lock washer and a hex nut onto the same stud as the cable strength member bracket. Install the “L” retention bracket onto the same stud and secure it with a lock washer and hex nut. Make sure that the retention bracket is flush with the micro duct when the bracket is secured onto the stud. Secure the micro duct to the retention bracket with a hose clamp.



Step #13 Re-tighten all cable cap bolts (Step #11) to assure that the cable caps are fully seated. When using a can wrench or nut driver, the installed torque is 35 to 40 in-lbs.

SAFETY CONSIDERATIONS

This application procedure is not intended to supersede any company construction or safety standards. This procedure is offered only to illustrate safe application for the individual. **FAILURE TO FOLLOW THESE PROCEDURES MAY RESULT IN PERSONAL INJURY OR DEATH.**

Do not modify this product under any circumstances.

This product is intended for use by trained technicians only. **This product should not be used by anyone who is not familiar with, and not trained to use it.**

When working in the area of energized lines, extra care should be taken to prevent accidental electrical contact.

For proper performance and personal safety, be sure to select the proper size PREFORMED™ product before application.

PREFORMED products are precision devices. To insure proper performance, they should be stored in cartons under cover and handled carefully.



PREFORMED LINE PRODUCTS

P.O. Box 91129, Cleveland, Ohio 44101 • 440.461.5200 • www.preformed.com • e-mail: inquiries@preformed.com

SP3408