

Side-of-Pole Mount for 1 Modules (SPM1) For Module Type C

ASSEMBLY INSTRUCTIONS

step-by-step
assembly and installation

Side-of-Pole Mount for 1 Module (SPM1) For Module Type C

A few words about the product

The SPM1 for module type C is designed to mount on 2”- 3.5” O.D. pipe (installer supplied). Options are available for mounting to larger diameter poles.

Pipe size and foundation requirements are based on several factors including the array surface area, maximum design wind speed, exposure category, soil type, steepest expected tilt angle, and above-ground clearance.

For foundation and pipe size recommendations on a specific installation please contact us at:

Phone: 800-260-3792

Email: info@plpsolar.com

About these Assembly Instructions

These instructions...

- Are intended to be used by individuals with sufficient technical skills for the task. Knowledge and use of hand tools, measuring devices and torque values is also required.
- Include various precautions in the forms of Notes, Cautions, and Warnings. These are to assist in the assembly process and/or to draw attention to the fact that certain assembly steps may be dangerous and could cause serious personal injury and/or damage to components. Following the step-by-step procedures and these precautions should minimize the risk of any personal injury or damage to components while making the installation not only safe but an efficient process.

WARNING:

Follow the procedures and precautions in these instructions carefully.

Required Tools

- 7/16 inch wrench or socket for 1/4 inch module hardware
- 9/16 inch wrench or socket for 3/8 inch hardware
- Torque wrench (not absolutely necessary)
- Ratchet wrench
- Ratchet extension bar

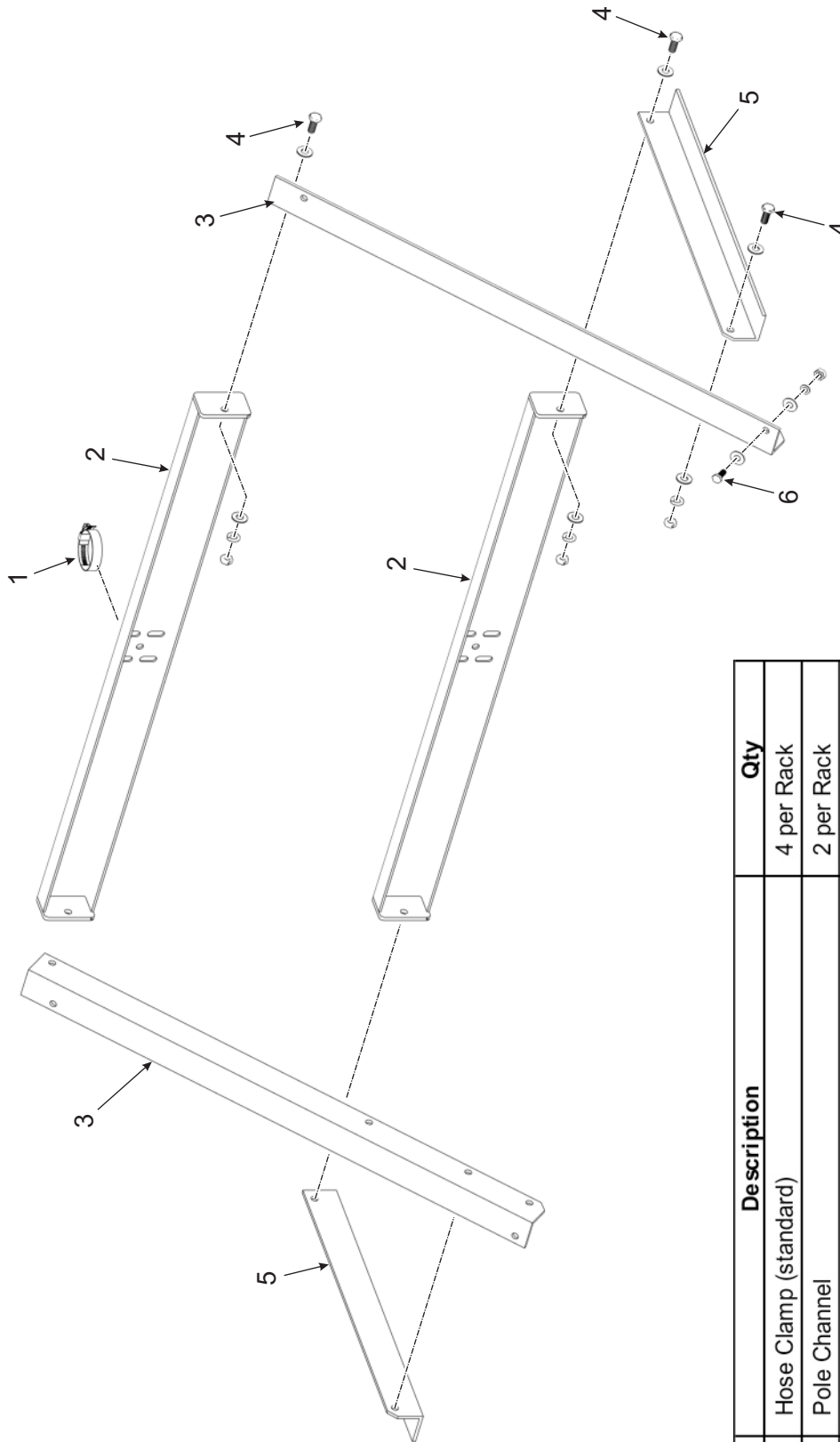

Item	Description	Qty
1	Hose Clamp (standard)	4 per Rack
2	Pole Channel	2 per Rack
3	Module Rail (left & right)	2 per Rack
4	3/8" x 1" hex bolt, lock washer, flat washers	6 sets per Rack
5	Strut	2 per Rack
6	1/4" x 3/4" hex bolt, lock washer, flat washers, nut	4 sets per Rack

Side-of-Pole Mount for 1 Module for Module Type C Parts Identification

How the PV Module Tilt Angle is Set

CAUTION:

Use care while working around the structure during assembly. There could be components that create hazards or obstruct free movement, causing serious bodily injury. Many of these are at head/eye level. Move slowly and with care around the work area.

Before assembly, determine what the PV Module tilt angle will be. This is critical because during assembly, certain components must be assembled in a particular manner in order to achieve that desired tilt.

The vertical span between the two Pole Channels along with the Strut attachment to one of the three attachment points (a, b, or c) of the Module Rails determine the final tilt angle of the Module. The figure below identifies seven common tilt angles and the unique combination of Pole Channel span along with the Strut attachment point to the Module Rail. Although other tilt angles are possible, these below address the most common tilt angles.

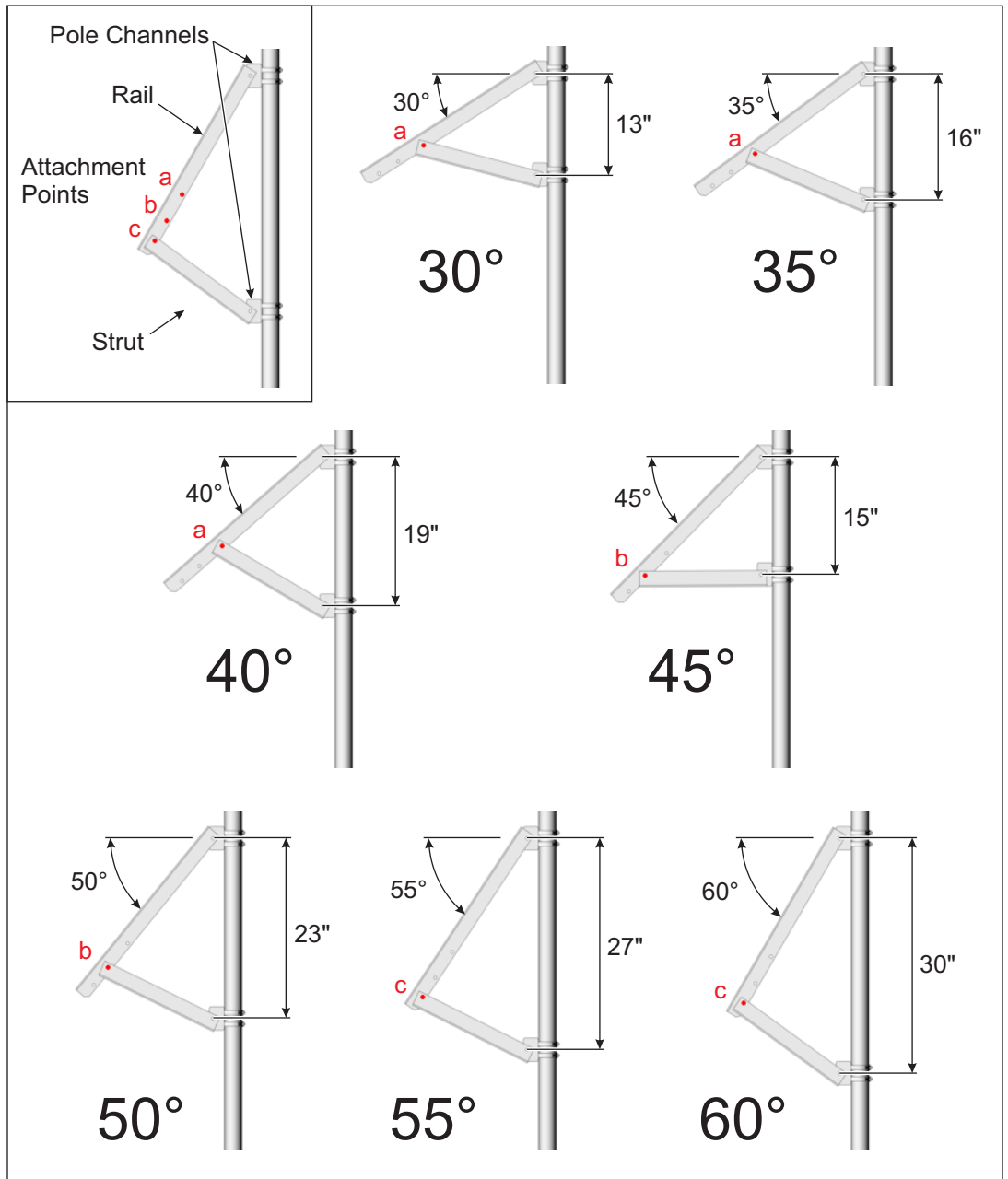

Figure 1-1: Module Tilt Angles and Pole Channel Spacing

Step 1: Attach Pole Channels to Mounting Pole

Before installing, the Pole Channels verify that the Mounting Pole is plumb to the ground and hasn't shifted or leaned while the concrete footing has cured.

The two Pole Channels are secured to the Mounting Pole using Hose Clamps. The span between the two Pole Channels ultimately determines the tilt angle of the PV Module. Therefore, before proceeding, determine what the angle of the Module will be and then refer to Figure 1-1 to locate the span measurement between the two Pole Channels based on the desired tilt angle of the PV Module. For example, on a 30-degree tilt the span between Pole Channels is 13 inches center to center.

Measure and mark the mounting locations of the two Pole Channels on the Mounting Pole. Then install the lower Pole Channel followed by the upper Pole Channel.

There are two methods of installing the Pole Channels on the Mounting Pole. The first is to first install the Hose Clamps on the Pole Channel and slip the Hose Clamps and Pole Channel over the top of the Mounting Pipe. The second is to hold the Pole Channel against the Mounting Pipe and thread the Hose Clamps through the vertical slots of the Pole Channel and around the Mounting Pole. The second method is generally used when the top of the Mounting Pole is not accessible. For demonstration purposes, these instructions detail the first method.

Prepare the Pole Channels by installing the two Hose Clamps on each. The Hose Clamps pass through the two sets of vertical slotted holes of the Pole Channel.

- A. Unscrew the two Hose Clamps and pass the loose ends through the two vertical slots of the Pole Channel, positioning the screw housing on the backside of the Pole Channel. Secure the loose end by screwing them back into their screw housing. Do this on both Pole Channels. (See Figure 1-2)

NOTE:

Depending on access to the top of the Mounting Pole, the Hose Clamps and Pole Channel can either be slipped over the top of the Mounting Pole or attached anywhere along the Mounting Pole.

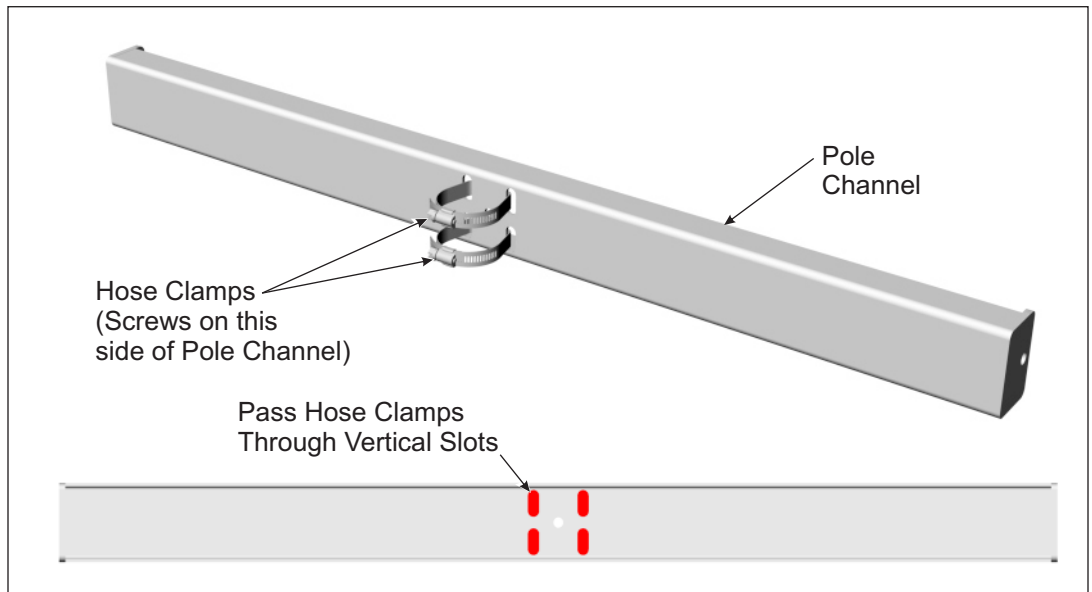

Figure 1-2: Installing Hose Clamps on Pole Channel

- B. Install the lower Pole Channel by slipping the Hose Clamps and Pole Channel over the top of Mounting Pole, sliding it down to its pre-determined and previously marked vertical position on the Mounting Pole.
- C. Rotate the Pole Channel so it is facing south. (See Figure 1-3)
- D. Tighten the two Hose Clamps securing it to the Pole Channel.

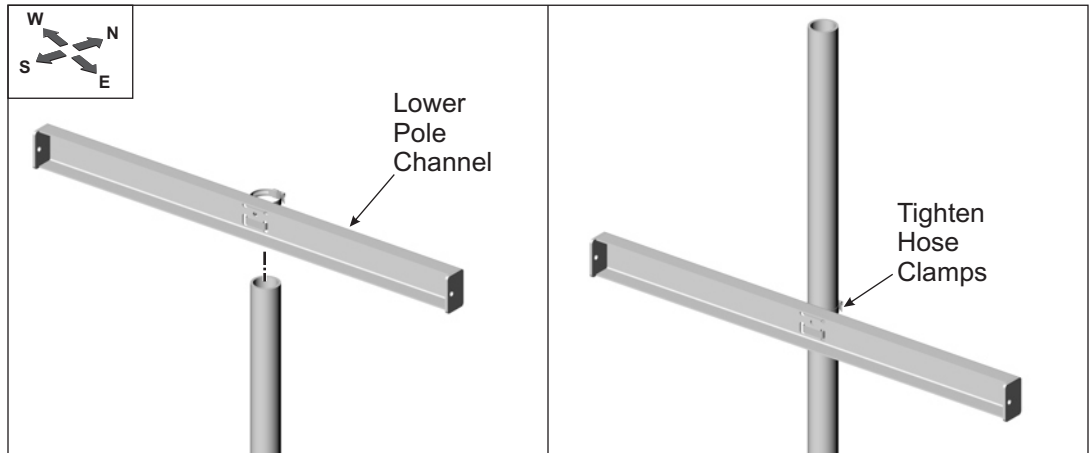

Figure 1-3: Installing Lower Pole Channel

- E. Install the upper Pole Channel in the same manner, aligning it to its pre-determined and previously marked vertical position on the Mounting Pole.
- F. Rotate the Pole Channel so it is facing south. (See Figure 1-4)
- G. Tighten the two Hose Clamps securing the Pole Channel to the Mounting Pole.

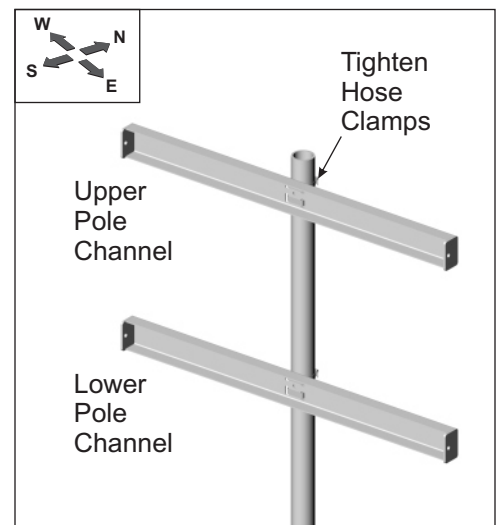

Figure 1-4: Installing Upper Pole Channel

Step 2: Attaching Struts to Lower Pole Channel

The two Struts are attached to the ends of the lower Pole Channel using 3/8" x 1" hex bolts and hardware. (See Figure 2-1)

- A. Orient and align the left Strut as shown in Figure 2-1. Secure with one 3/8" x 1" hex bolt, lock washer, flat washers, and Hex Nut, finger tighten for now.
- B. Continue in this manner and install the right Module Arm. Again, finger tighten for now.

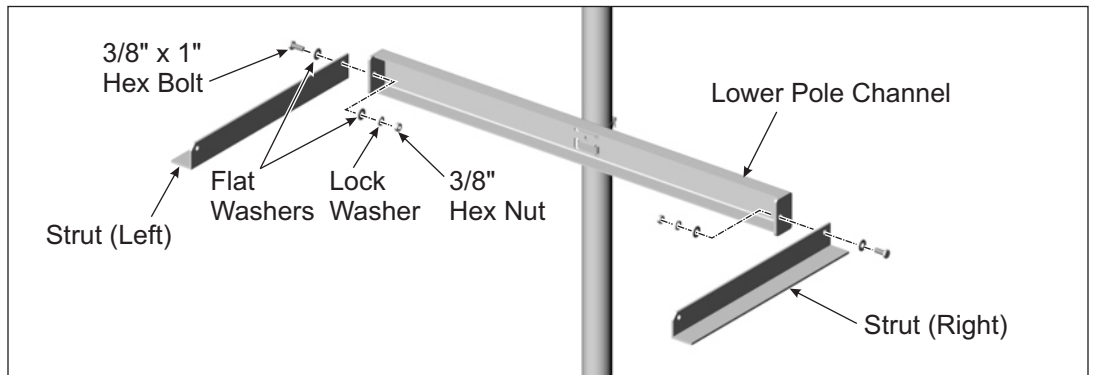

Figure 2-1: Attaching Module Arm to Pole Channel

Step 3: Attaching Module Rails to Upper Pole Channel

The two Module Rails are attached to the ends of the upper Pole Channel using 3/8" x 1" hex bolts and hardware. (See Figure 3-1)

- A. Orient and align the left Module Rail as shown in Figure 3-1. Secure with one 3/8" x 1" hex bolt, lock washer, flat washers, and Hex Nut. Finger tighten for now.
- B. Continue in this manner and install the right Module Rail, finger tighten for now.

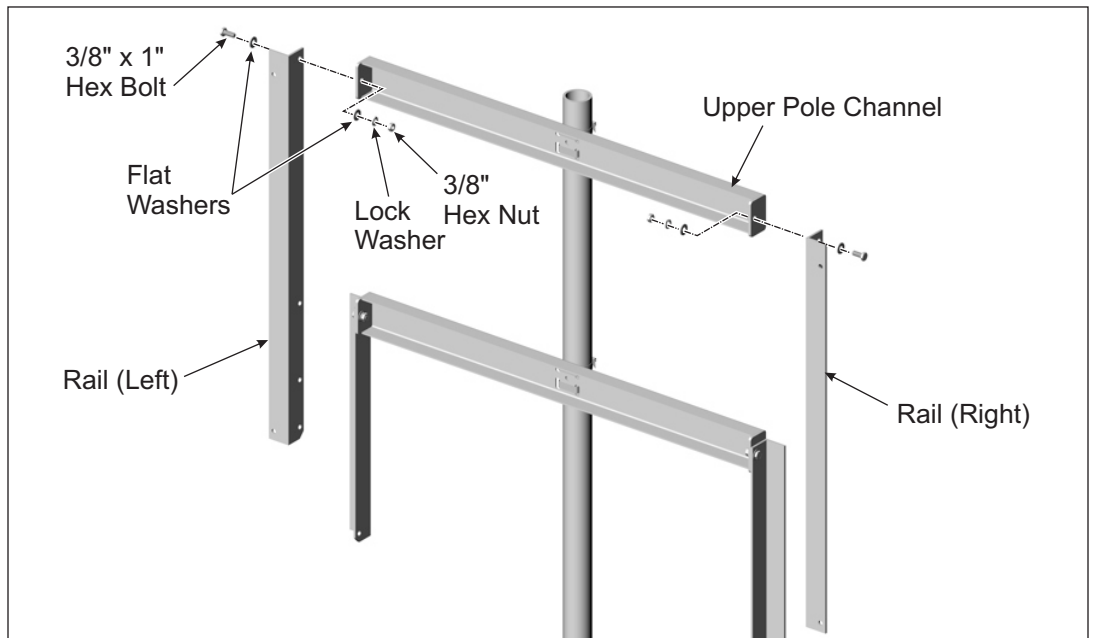

Figure 3-1: Attaching Rails to Pole Channel

Step 4: Joining the Module Rails and Struts

The two Struts are attached to the Module Rails using 3/8" x 1" hex bolts and hardware. Be mindful of the three attachment points (a, b, and c) on the Module Rails and chose the point that matches the desired Module tilt angle from Figure 1-1.

- A. Orient and align the mounting hole at the end of the left Strut with the chosen attachment point (a, b, or c) on the left Module Rail.
- B. Secure with the 3/8" x 1" bolt, lock washer, flat washers, and Hex Nut. **Torque to 32-34 ft.-lbs.**
- C. Continue in this manner to install the right Module Rail.

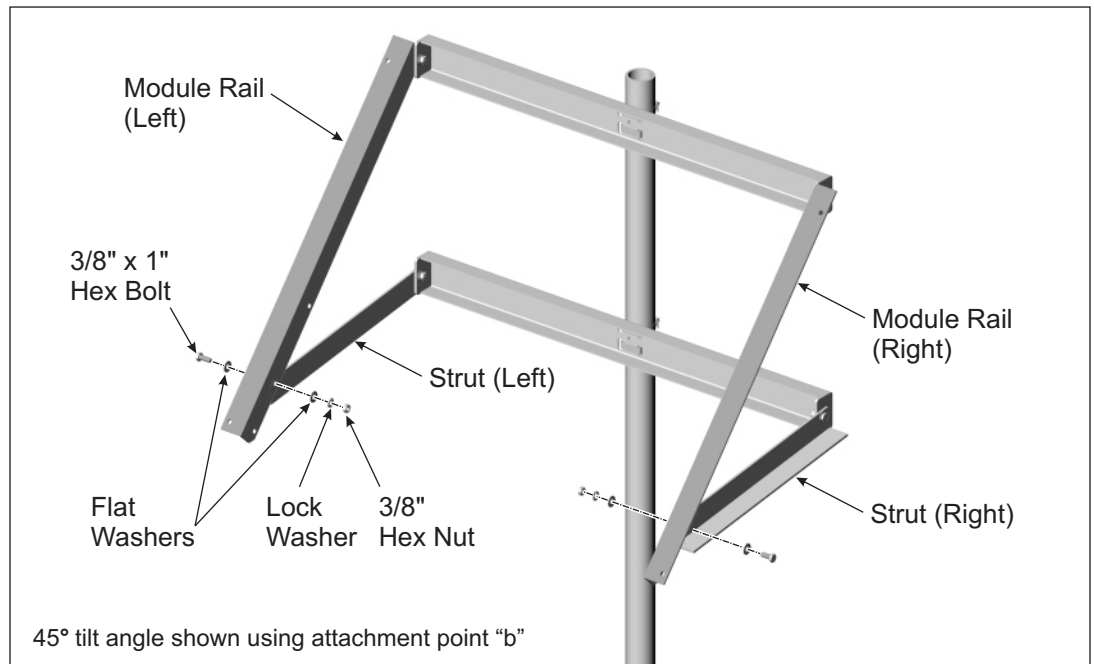

Figure 4-1: Joining Module Rails to Struts

- D. Return and tighten the hardware securing the Module Rails and Struts to the upper and lower Pole Channels. **Torque to 32-34 ft.-lbs.**

Step 5: Attach PV Module to Module Rails

PV Modules are secured to the Module Rails using 1/4" x 3/4" bolts and hardware.

- A. Place the Module on the Module Rails. While one person holds the Module in place, align the mounting holes and secure with 1/4" x 3/4" bolts and hardware. Each Module has four attachment points. **Torque to 6-8 ft.-lbs.** (See Figure 3-1)

CAUTION:

This is a two person activity. The PV Module is heavy and unstable before fully secured to the Module Rails. The PV Module must be held in place by one person while the second person aligns and secures it to the Module Rails. Failure to do so could lead to serious personal injury and damaged components.

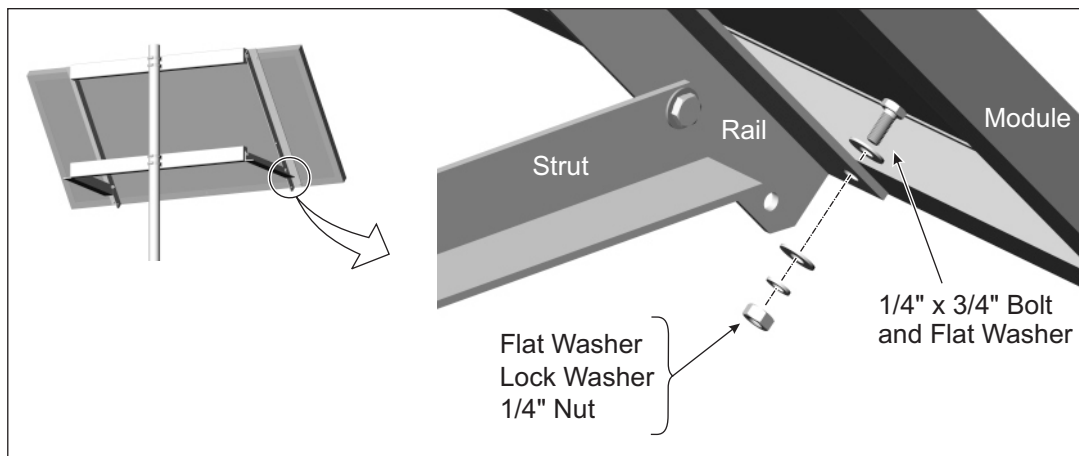

Figure 5-1: Attaching Module to Rail



PREFORMED LINE PRODUCTS

Albuquerque Office
1700 Louisiana Blvd., Suite 130
Albuquerque, NM 87110

Corporate Headquarters
660 Beta Drive
Mayfield Village, OH 44143

Telephone: 800.260.3792
Fax: 505.889.3548
www.preformed.com
E-mail: info@plpsolar.com

© 2017 Preformed Line Products
PCN 022212-1 Version 1, Rev A
SP3338-2