

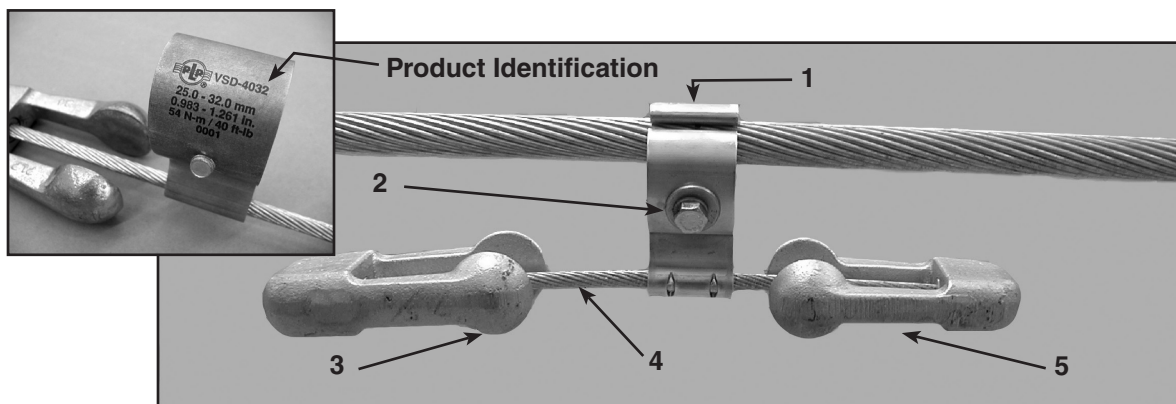

VORTX™ Vibration Damper

Be sure to read and completely understand this procedure before applying product. Be sure to select the proper PREFORMED™ product before installation.



VORTX VIBRATION DAMPER

NOMENCLATURE

1. **Clamp & Keeper:** The Clamp has an extruded hook shaped profile to hang onto the cable or conductor while tightening the keeper. As shown above, the lower part of the clamp is crimped onto the messenger (item 4). Together, the keeper and clamp capture the conductor to hold the damper assembly firmly onto the conductor or cable. Product identification, installation torque, and lot number are permanently etched on the clamp.
2. The bolt, washer, and lock washer are used to fasten the keeper to the clamp and secure the entire damper assembly to the cable or conductor. Washer and lock washer are necessary for proper installation.
3. **Large Damper Weight:** The damper design shown above has two weight sizes, this provides up to 4 resonant response frequencies (two for the large weight and two for the small weight) for more effective protection.
4. **Messenger:** Flexible Metal Strand
5. **Small Damper Weight**

DESCRIPTION

VORTX Vibration Dampers can be clamped directly onto most aluminum based conductors including ACSR, ACAR, ACCR. PLP® Protector Rods should be considered for applications on aluminum conductors with relatively soft outer aluminum strand construction such as ACSS. Protector rods are designed to reduce direct clamping stress on cable vulnerable to surface or core damage. This includes fiber optic cable designs such as ADSS and OPGW.

VORTX Vibration Dampers are classified as a Stockbridge type damper. This type of damper responds to wind induced line vibration that is characterized by high frequency, low amplitude motion also known as aeolian vibration.

Stockbridge dampers have specific performance characteristics that require strategic placement on the line to counter vibration activity. Placement information shall be provided to the installer to assure that the damper will provide effective protection.

This application procedure provides general instructions for damper installation and should be used in conjunction with placement information.

DESCRIPTION Cont'd:

Supplemental placement information refers to locations A, B, C, and D for the first four dampers as measured from the respective hardware - See figure below. Spans that require additional protection are usually considered special long span applications and may require dampers placed midspan.

Cable Attachment hardware with multilayer rod design such as the THERMOLIGN® Suspension and FIBERLIGN® Suspension, are exceptions as distance is measured from the outer rod ends for damper location (See Step 2). Photo 1 shows the minimum distance required from the rod ends as 50 mm (2 inches).

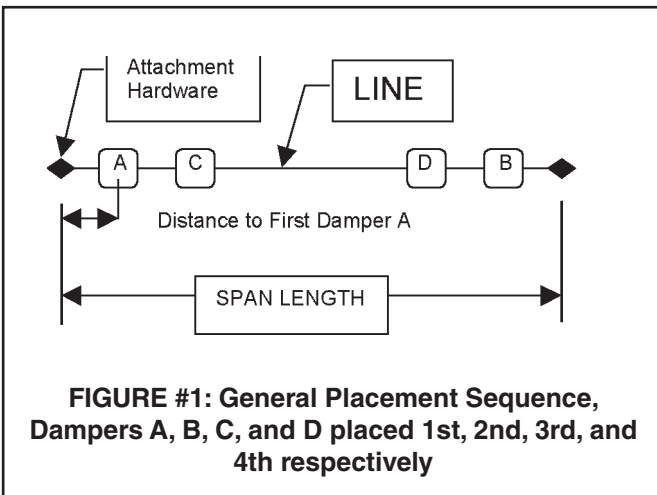

NOTE: Orientation is not critical for damper performance, i.e., the large weight (or longer messenger leg) may be clamped on the cable faced toward or away from the structure. For two closely placed dampers, it may be beneficial to face the small weights (or shorter messenger legs) to avoid interference.

STANDARD APPLICATION OF VORTX™ VIBRATION DAMPER

STEP #1 Measure and mark the appropriate distance as given from the placement information. Placement distances are measured from attachment hardware for damper locations A and B (see Figure #1), and from dampers A and B for damper locations C and D. See paragraph below for examples of placement from Suspensions, and for examples of placement from Dead-ends.

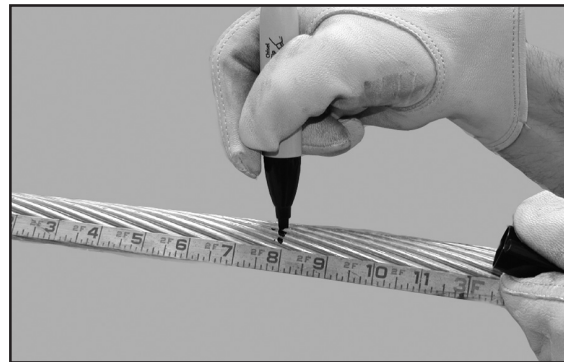

Measure and mark location of Damper

Suspension: When measuring from Suspension or Support hardware, distance to dampers A and B is measured from the center of the hardware for most applications. Examples of the measurements (labeled "A" & "B") are shown in Figures #2 & #3.

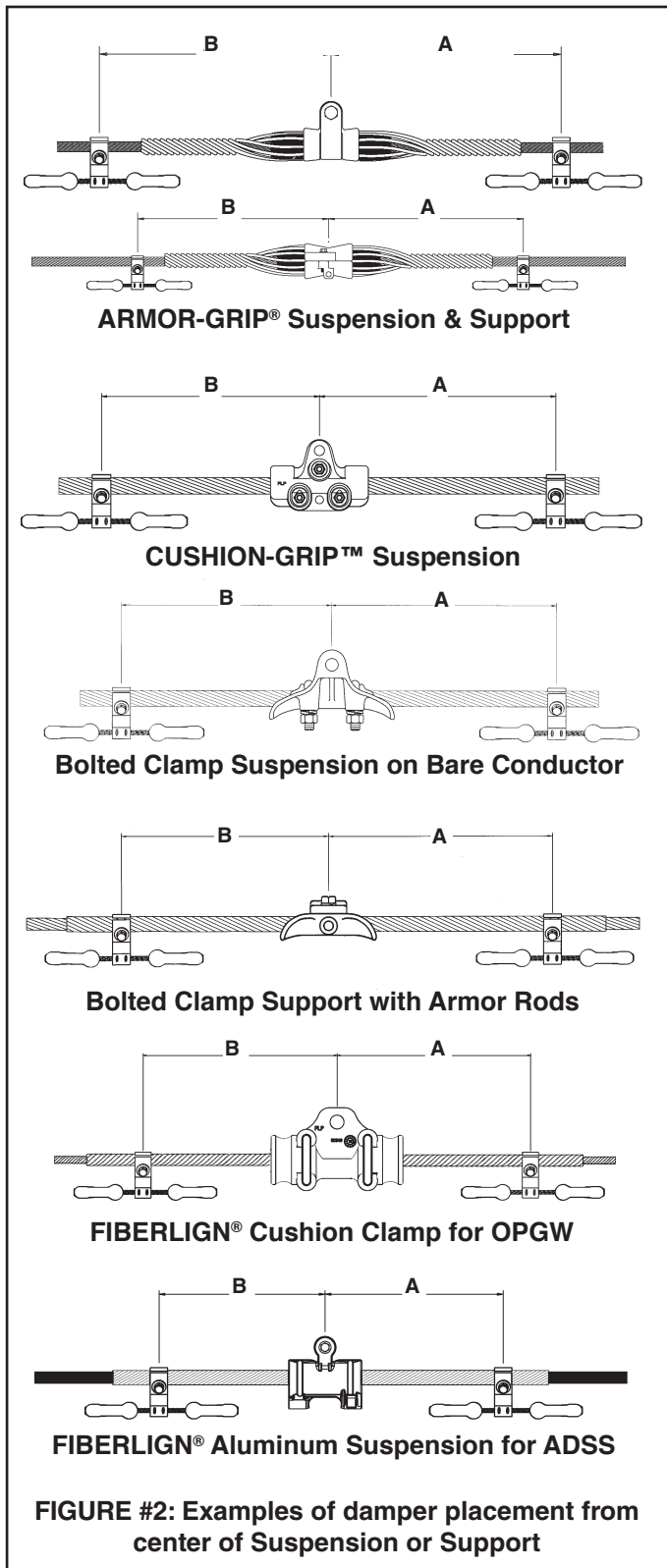

NOTE: For ACSR, ACAR, and Shield Wire applications, dampers may be placed directly onto the conductor, or over a single layer of armor rods. There is a tolerance of +/- 3" (7.6cm) for damper placement. Be sure that the end of the clamp is at least 2" (5.1cm) from the ends of the rods, regardless of whether the damper is placed on the rods or the damper is placed off of the rods.

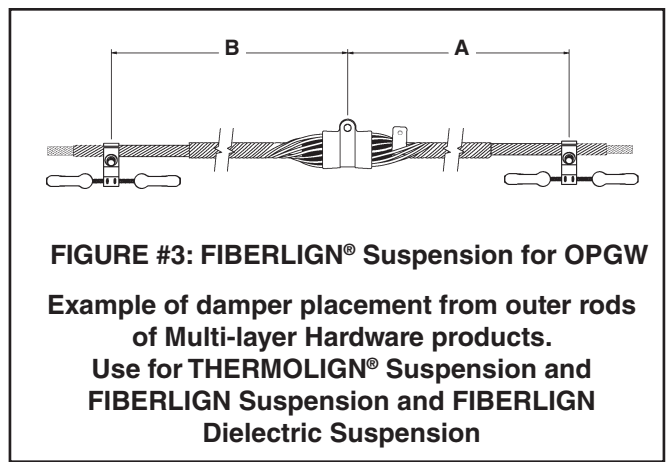

NOTE: More than one layer of rods increases the stiffness near the attachment hardware body. Consequently, the first damper is typically placed at least 2" (5.1cm) beyond the ends of the outer layer of rods as shown in Photo #1. There is a tolerance of +/- 3" (7.6cm) for damper placement. Be sure that the end of the clamp is at least 2" (5.1cm) from the ends of the rods, regardless of whether the damper is placed on the rods or the damper is placed off of the rods.

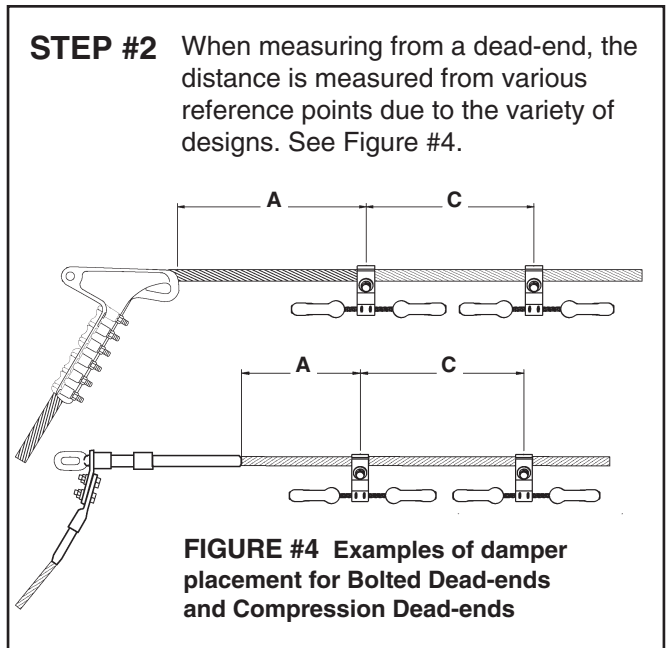
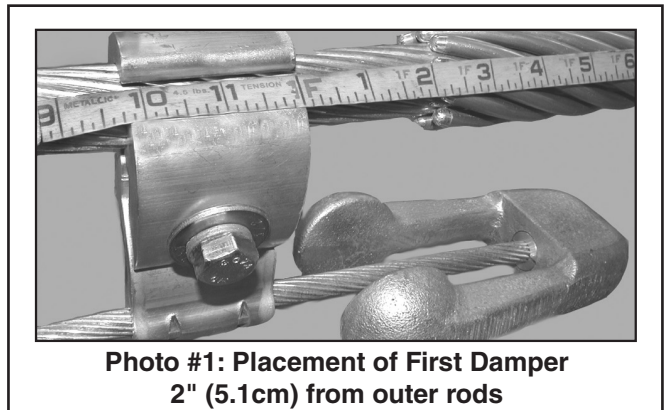

STEP #2 continued

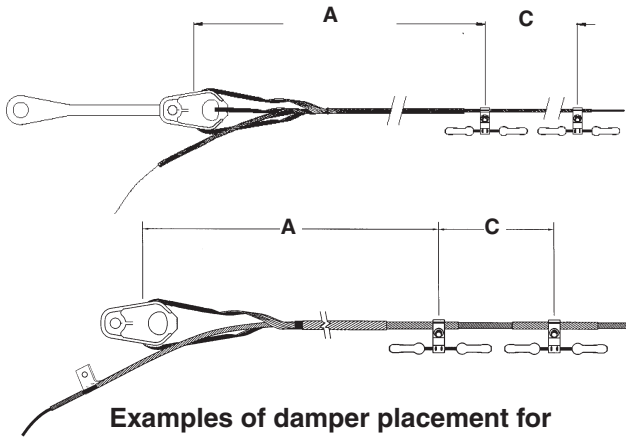

Examples of damper placement for THERMOLIGN® Dead-end and FIBERLIGN Formed Wire Dead-end.

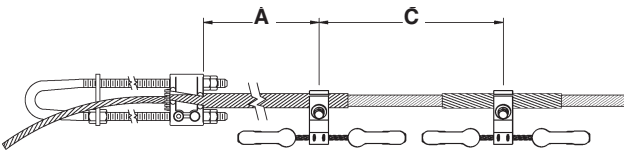

Example of damper placement for FIBERLIGN Dead-end (U-bolt style).

STEP #3 Hang the clamp of the damper and center on the placement mark. See photo below.

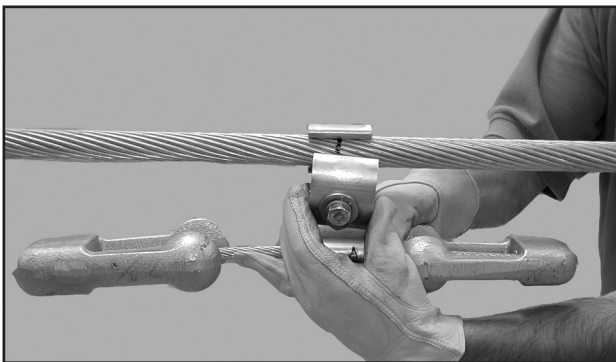

STEP #4 Tighten bolt to bring keeper against the clamp. Proper torque levels are listed in Table 1.

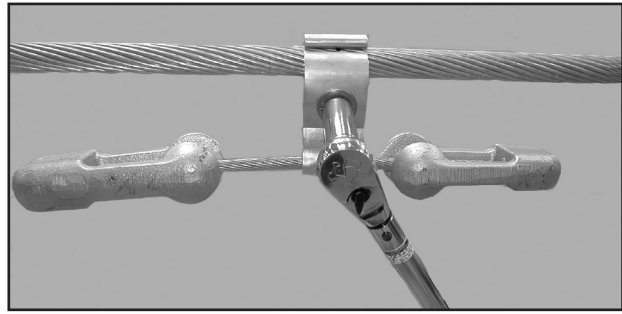

STEP #5 The completed single damper.

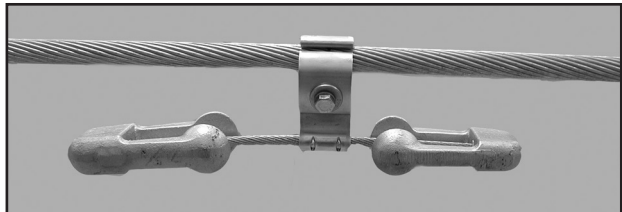

NOTE: Orientation is not critical for damper performance. For two dampers closely placed, it may be beneficial to face the short messenger leg from each damper to avoid interference between the dampers.

STEP #6 For applications over protector rods, follow PLP application procedure SP2952. Below shows an application over Protector Rods.

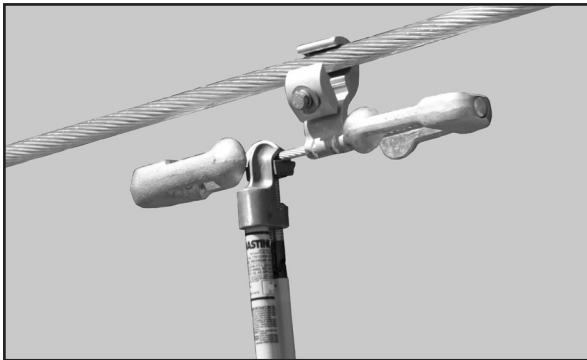

TABLE 1: INSTALLATION TORQUE LEVEL									
CLAMP CODE*	CLAMP RANGE				BOLT THREAD SIZE	WRENCH SIZE		TORQUE	
	Millimeters		Inches			Metric	English	Metric	English
	Min	Max	Min	Max		mm	in	N-m	Ft-lb
16	12.3	15.5	0.483	0.612	M12	19	3/4	41	30
20	15.5	20.0	0.612	0.786	M12	19	3/4	41	30
25	20.0	25.0	0.786	0.983	M12	19	3/4	54	40
32	25.0	32.0	0.983	1.261	M12	19	3/4	54	40
40	32.0	40.1	1.261	1.579	M12	19	3/4	54	40
43**	38.1	42.7	1.500	1.680	M12	19	3/4	61	45
49**	43.2	49.5	1.700	1.950	M12	19	3/4	61	45
50	40.1	50.0	1.579	1.970	M12	19	3/4	54	40
61	50.0	61.5	1.970	2.422	M12	19	3/4	54	40

*NOTE: The third and fourth digits of the Catalog No. represent the clamp code. Ex. VSD4032, 32 is clamp code.
 **EHV Clamps

HOTSTICK APPLICATION OF VORTX™ VIBRATION DAMPER

STEP #7 Follow Step 1 & Step 2 of this application procedure before attempting to hotstick the VORTX Damper. Loosen the clamp on the damper, ensuring that it can fit over the conductor. Hook the VORTX Damper with the hotstick tool onto the line, ensuring the damper is secure.



STEP #8 Attach a tool that will tighten the bolt on the keeper to your hotstick. Proceed to tighten the bolt against the keeper to reach the proper torque level. Refer to Table 1 for the required torque levels.

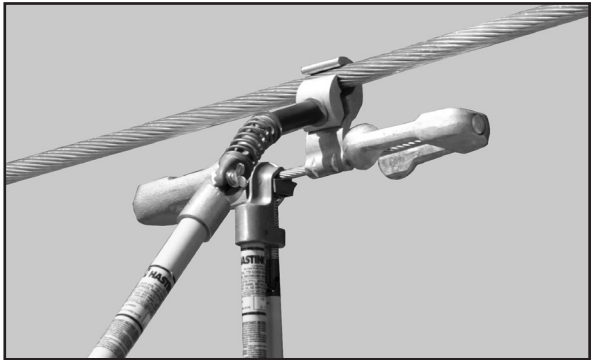
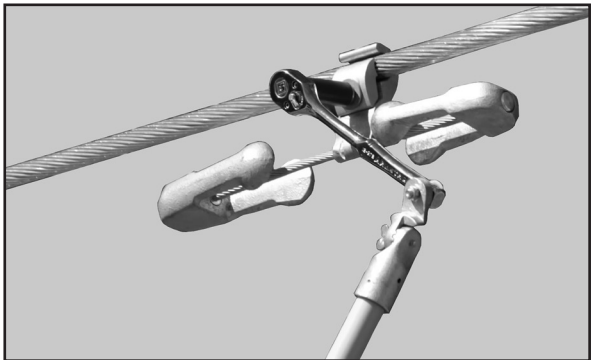

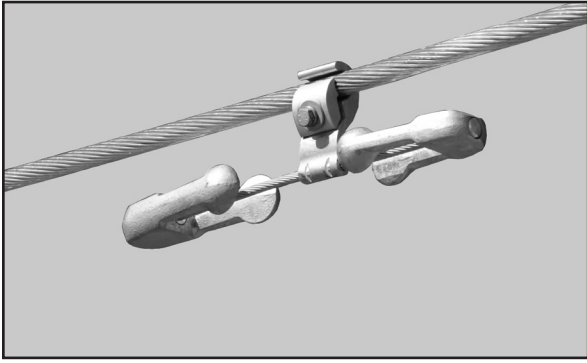

STEP #9 The installation is now complete.

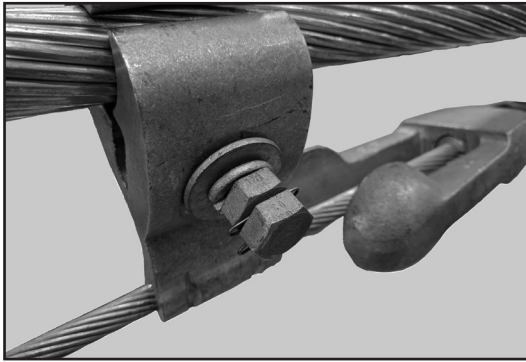

**BREAKAWAY BOLT APPLICATION
OF VORTX™ VIBRATION DAMPER**

STEP #10 Ensure the spring clip is attached to the head of the bolt.



STEP #11 Using an appropriate socket wrench or tool, tighten the bolt until the head shears off at the spring clip.



STEP #12 Discard the bolt head and spring clip. The installation is complete.

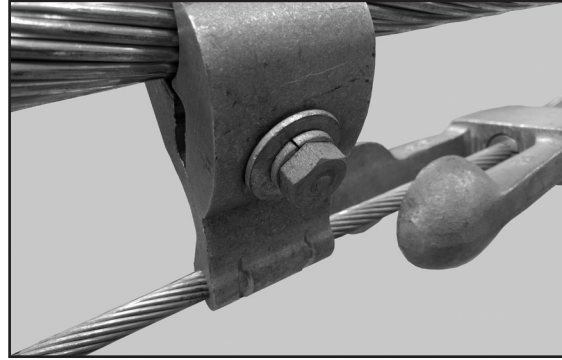

NOTE: If the VORTX Damper is to be removed for any reason, a new breakaway head bolt must be used.

SAFETY CONSIDERATIONS

This application procedure is not intended to supersede any company construction or safety standards. This procedure is offered only to illustrate safe application for the individual.

FAILURE TO FOLLOW THESE PROCEDURES MAY RESULT IN PERSONAL INJURY OR DEATH.

This product may be removed and reinstalled during the initial installation if it is in good condition. After extended service life, it is recommended the product not be reused once removed from service.

Do not modify this product under any circumstances.

This product is intended for use by trained technicians only. **This product should not be used by anyone who is not familiar with, and not trained to use it.**

When working in the area of energized lines, extra care should be taken to prevent accidental electrical contact.

For proper performance and personal safety, be sure to select the proper size PREFORMED™ product before application.

PREFORMED products are precision devices. To insure proper performance, they should be stored in cartons under cover and handled carefully.



PREFORMED LINE PRODUCTS

P.O. Box 91129, Cleveland, Ohio 44101 • 440.461.5200 • www.preformed.com • e-mail: inquiries@preformed.com

SP2993-7